



# 2017/2018 PROFESSIONAL PNEUMATIC FITTINGS

专业气动接头



正荷自动化设备(上海)有限公司

地址: 上海市沪松公路3778号1号楼3A 邮编: 201600 邮箱: info@pisco-hanhae.com  
电话: 021-37773226 传真: 021-67685432 客服电话: 13917315228 13818102609

[www.ilsin.cn](http://www.ilsin.cn)



企业使命：用我们的产品造福更多的人

企业宗旨：发展员工、成就客户、回报股东、强大国家

核心价值：合作共赢、务实创新

经营理念：诚信、务实、敬业、创新

INTRODUCTION TO

# ILSIN BRAND

## ILSIN品牌简介



ILSIN品牌成立于2008年，公司专业生产气动元件及自动化设备辅助元件。自公司成立以来，致力于出口业务，产品远销欧美、日韩等国。2015年在上海建立生产基地开始国内销售。

优质的产品来自先进的设计、可靠的生产手段、精选的配件及严格的管理。ILSIN公司以高质量的开发设计队伍，全方位的销售网络，高品质的产品来服务客户。

创新与发展是时时向前的。公司一直秉承“用我们的产品造福更多的人”的企业使命，并不断的向“业界旗舰”的目标迈进。热情做事，诚实做人，敬业创新一直是ILSIN人的工作态度和人生准则。

2017年是ILSIN加快步伐、快速发展的一年，让使用ILSIN品牌的客户成为我们的股东是我们的承诺，也是我们奋斗的最大动力。

### LOGO / 标准色 / 辅助色



ILSIN Blue  
PANTONE 286C  
C100 M85 Y10 K5

ILSIN Blue  
PANTONE 2995C  
C80 M17 Y8 K0



Dark Gray  
Pantone Cool Gray11C



Silver  
Pantone 877C



Gold  
Pantone 873C

# Contents 目录



快速R/G螺纹接头  
R/G thread one-touch fittings 1



调速节流阀  
Speed controlles 11



手阀  
Hand valves 13



快拧式FN系列气动管接头 (全铜镀镍)  
FN Series metal rapid fittings(brass & nickle-plate) 28



卡套式FK系列气动管接头 (全铜镀镍)  
FK Series metal pipe joint fittings (brass & nickle-plate) 29



活络式FW系列管接头 (全铜镀镍)  
FW Series metal plug-in fittings (brass & nickle-plate) 30



截止阀  
Stop Fittings 15



单向阀  
Check Valves 17



迷你接头  
Compact One -Touch Fittings 19



宝塔式FB系列管接头 (全铜镀镍)  
FB Series metal stand pipe fitting s(brass & nickle-plate) 31



内外螺纹接头系列  
Female and male thread connector series 32



YWS内置轴承高低速旋转接头系列  
YWS built-in bearing high-low-speed rotary connector series 33



消声器  
Silencers 22



插入式FCR系列气动管接头 (全铜镀镍)  
FCR Series metal push-in fittings (brass& nickle-plate) 24



QLAW系列全黄铜镀镍插入接头式单向节流阀  
QLAW Metal push-in speed controllers 26



通用附件 (全铜镀镍)  
Metal interconverted accessories (brass & nickel-plate) 34



PU 气管 35



Pa气管 36

## 快速接头 ONE-TOUCH FITTINGS

### 特点 Features

主题是可转向的结构，所以提高了铺设管子的效率。(PL, PH, PB 等型号)  
随着螺纹及连接管径的不同，规格也不同。  
PC 螺纹内刻有六角扳手孔，所以即使在狭窄处安装也十分容易。  
螺纹处有 O 型圈或密封胶，所以不用密封处理就可以直接安装。

### 使用范围说明 Specifications

|        |                                 |                                     |
|--------|---------------------------------|-------------------------------------|
| 使用流体   | Air (No other gases or liquids) |                                     |
| 使用压力   | 0-150PSI                        | 0-10Kgf/cm <sup>2</sup> (0-1000kPa) |
| 负压     | -29.5 in Hg                     | -750mmHg (10Torr)                   |
| 使用温度范围 | 32-140° F                       | -10-60°C                            |
| 使用气管种类 | Polyurethane and nylon          |                                     |

### 产品标志形色 Product code system



①型号  
②管径大小 (D)

| Code | Metric size |    |    |    |    |    | Inch size |      |     |      |     |     |
|------|-------------|----|----|----|----|----|-----------|------|-----|------|-----|-----|
|      | 04          | 06 | 08 | 10 | 12 | 16 | 5/32      | 3/16 | 1/4 | 5/16 | 3/8 | 1/2 |
| Dia  | 4           | 6  | 8  | 10 | 12 | 16 | 5/32      | 3/16 | 1/4 | 5/16 | 3/8 | 1/2 |

③螺纹规格

| Code | Metric size |        | Taper pipe thread |      |      |      |
|------|-------------|--------|-------------------|------|------|------|
|      | M5          | M6     | 01                | 02   | 03   | 04   |
| Size | M5x0.8      | M6x1.0 | R1/8              | R1/4 | R3/8 | R1/2 |

| Code | Unified fine thread |        | American standard taper pipe thread |        |        |  |
|------|---------------------|--------|-------------------------------------|--------|--------|--|
|      | U10U                | N01U   | N02U                                | N03U   | N04U   |  |
| Size | 10-32UNF            | NPT1/8 | NPT1/4                              | NPT3/8 | NPT1/2 |  |

### 结构图 Structural diagram

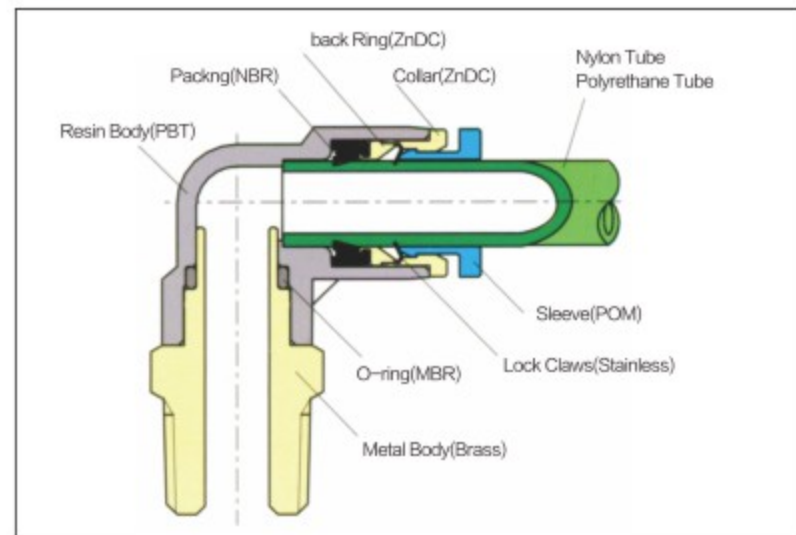

## 快速接头 ONE-TOUCH FITTINGS



IPC 螺纹六角直通 Male straight

| Model (φD-T)           |          |          |          |
|------------------------|----------|----------|----------|
| Tube(metric)-thread(R) |          |          |          |
| IPC04-M5               | IPC06-04 | IPC10-03 | IPC16-03 |
| IPC04-01               | IPC08-01 | IPC10-04 | IPC16-04 |
| IPC04-02               | IPC08-02 | IPC12-01 |          |
| IPC06-M5               | IPC08-03 | IPC12-02 |          |
| IPC06-01               | IPC08-04 | IPC12-03 |          |
| IPC06-02               | IPC10-01 | IPC12-04 |          |
| IPC06-03               | IPC10-02 | IPC16-02 |          |



IPOC 螺纹圆直通 Round male straight

| Model (φD-T)           |           |           |           |
|------------------------|-----------|-----------|-----------|
| Tube(metric)-thread(R) |           |           |           |
| IPOC04-M5              | IPOC06-04 | IPOC10-03 | IPOC16-03 |
| IPOC04-01              | IPOC08-01 | IPOC10-04 | IPOC16-04 |
| IPOC04-02              | IPOC08-02 | IPOC12-01 |           |
| IPOC06-M5              | IPOC08-03 | IPOC12-02 |           |
| IPOC06-01              | IPOC08-04 | IPOC12-03 |           |
| IPOC06-02              | IPOC10-01 | IPOC12-04 |           |
| IPOC06-03              | IPOC10-02 | IPOC16-02 |           |



IPCF 内螺纹直通 Female straight

| Model (φD-T)             |           |           |           |
|--------------------------|-----------|-----------|-----------|
| Tube(metric)-thread(R/G) |           |           |           |
| IPCF04-M5                | IPCF06-04 | IPCF10-03 | IPCF16-03 |
| IPCF04-01                | IPCF08-01 | IPCF10-04 | IPCF16-04 |
| IPCF04-02                | IPCF08-02 | IPCF12-01 |           |
| IPCF06-M5                | IPCF08-03 | IPCF12-02 |           |
| IPCF06-01                | IPCF08-04 | IPCF12-03 |           |
| IPCF06-02                | IPCF10-01 | IPCF12-04 |           |
| IPCF06-03                | IPCF10-02 | IPCF16-02 |           |



IPC-G 螺纹六角直通 Male straight

| Model (φD-T)           |           |           |           |
|------------------------|-----------|-----------|-----------|
| Tube(metric)-thread(G) |           |           |           |
| IPC04-M5               | IPC06-G04 | IPC10-G03 | IPC16-G03 |
| IPC04-G01              | IPC08-G01 | IPC10-G04 | IPC16-G04 |
| IPC04-G02              | IPC08-G02 | IPC12-G01 |           |
| IPC06-M5               | IPC08-G03 | IPC12-G02 |           |
| IPC06-G01              | IPC08-G04 | IPC12-G03 |           |
| IPC06-G02              | IPC10-G01 | IPC12-G04 |           |
| IPC06-G03              | IPC10-G02 | IPC16-G02 |           |



IPOC-G 螺纹圆直通 Round male straight

| Model (φD-T)           |            |            |            |
|------------------------|------------|------------|------------|
| Tube(metric)-thread(G) |            |            |            |
| IPOC04-M5              | IPOC06-G04 | IPOC10-G03 | IPOC16-G03 |
| IPOC04-G01             | IPOC08-G01 | IPOC10-G04 | IPOC16-G04 |
| IPOC04-G02             | IPOC08-G02 | IPOC12-G01 |            |
| IPOC06-M5              | IPOC08-G03 | IPOC12-G02 |            |
| IPOC06-G01             | IPOC08-G04 | IPOC12-G03 |            |
| IPOC06-G02             | IPOC10-G01 | IPOC12-G04 |            |
| IPOC06-G03             | IPOC10-G02 | IPOC16-G02 |            |



IPMF内螺纹隔板直通 Bulkhead female straight

| Model (φD-T)             |           |           |           |
|--------------------------|-----------|-----------|-----------|
| Tube(metric)-thread(R/G) |           |           |           |
| IPMF04-M5                | IPMF06-04 | IPMF10-03 | IPMF16-03 |
| IPMF04-01                | IPMF08-01 | IPMF10-04 | IPMF16-04 |
| IPMF04-02                | IPMF08-02 | IPMF12-01 |           |
| IPMF06-M5                | IPMF08-03 | IPMF12-02 |           |
| IPMF06-01                | IPMF08-04 | IPMF12-03 |           |
| IPMF06-02                | IPMF10-01 | IPMF12-04 |           |
| IPMF06-03                | IPMF10-02 | IPMF16-02 |           |

快速接头 ONE-TOUCH FITTINGS



IPM 隔板两通 Bulkhead union

| Model ( φD)            |  |  |  |
|------------------------|--|--|--|
| Tube(metric)-thread(R) |  |  |  |
| I PM04                 |  |  |  |
| I PM06                 |  |  |  |
| I PM08                 |  |  |  |
| I PM10                 |  |  |  |
| I PM12                 |  |  |  |
| I PM16                 |  |  |  |



IPLF L 型内螺纹两通 Female elbow

| Model ( φD-T)            |            |            |            |
|--------------------------|------------|------------|------------|
| Tube(metric)-thread(R/G) |            |            |            |
| I PLF04-M5               | I PLF06-04 | I PLF10-03 | I PLF16-03 |
| I PLF04-01               | I PLF08-01 | I PLF10-04 | I PLF16-04 |
| I PLF04-02               | I PLF08-02 | I PLF12-01 |            |
| I PLF06-M5               | I PLF08-03 | I PLF12-02 |            |
| I PLF06-01               | I PLF08-04 | I PLF12-03 |            |
| I PLF06-02               | I PLF10-01 | I PLF12-04 |            |
| I PLF06-03               | I PLF10-02 | I PLF16-02 |            |



IPL L 型螺纹两通 Male elbow

| Model ( φD-T)          |           |           |           |
|------------------------|-----------|-----------|-----------|
| Tube(metric)-thread(R) |           |           |           |
| I PL04-M5              | I PL06-04 | I PL10-03 | I PL16-03 |
| I PL04-01              | I PL08-01 | I PL10-04 | I PL16-04 |
| I PL04-02              | I PL08-02 | I PL12-01 |           |
| I PL06-M5              | I PL08-03 | I PL12-02 |           |
| I PL06-01              | I PL08-04 | I PL12-03 |           |
| I PL06-02              | I PL10-01 | I PL12-04 |           |
| I PL06-03              | I PL10-02 | I PL16-02 |           |



IPLM L 型隔板两通 Bulkhead union elbow

| Model ( φD)            |  |  |  |
|------------------------|--|--|--|
| Tube(metric)-thread(R) |  |  |  |
| I PLM04                |  |  |  |
| I PLM06                |  |  |  |
| I PLM08                |  |  |  |
| I PLM10                |  |  |  |
| I PLM12                |  |  |  |
| I PLM16                |  |  |  |



IPBF B 型内螺纹三通 Female branch T

| Model ( φD-T)            |            |            |            |
|--------------------------|------------|------------|------------|
| Tube(metric)-thread(R/G) |            |            |            |
| I PBF04-M5               | I PBF06-04 | I PBF10-03 | I PBF16-03 |
| I PBF04-01               | I PBF08-01 | I PBF10-04 | I PBF16-04 |
| I PBF04-02               | I PBF08-02 | I PBF12-01 |            |
| I PBF06-M5               | I PBF08-03 | I PBF12-02 |            |
| I PBF06-01               | I PBF08-04 | I PBF12-03 |            |
| I PBF06-02               | I PBF10-01 | I PBF12-04 |            |
| I PBF06-03               | I PBF10-02 | I PBF16-02 |            |



IPL-G L 型螺纹两通 Male elbow

| Model ( φD-T)          |            |            |            |
|------------------------|------------|------------|------------|
| Tube(metric)-thread(G) |            |            |            |
| I PL04-M5              | I PL06-G04 | I PL10-G03 | I PL16-G03 |
| I PL04-G01             | I PL08-G01 | I PL10-G04 | I PL16-G04 |
| I PL04-G02             | I PL08-G02 | I PL12-G01 |            |
| I PL06-M5              | I PL08-G03 | I PL12-G02 |            |
| I PL06-G01             | I PL08-G04 | I PL12-G03 |            |
| I PL06-G02             | I PL10-G01 | I PL12-G04 |            |
| I PL06-G03             | I PL10-G02 | I PL16-G02 |            |

快速接头 ONE-TOUCH FITTINGS



IPLL L 型加长螺纹两通 Extended male elbow

| Model ( φD-T)          |            |            |            |
|------------------------|------------|------------|------------|
| Tube(metric)-thread(R) |            |            |            |
| I PLL04-M5             | I PLL06-04 | I PLL10-03 | I PLL16-03 |
| I PLL04-01             | I PLL08-01 | I PLL10-04 | I PLL16-04 |
| I PLL04-02             | I PLL08-02 | I PLL12-01 |            |
| I PLL06-M5             | I PLL08-03 | I PLL12-02 |            |
| I PLL06-01             | I PLL08-04 | I PLL12-03 |            |
| I PLL06-02             | I PLL10-01 | I PLL12-04 |            |
| I PLL06-03             | I PLL10-02 | I PLL16-02 |            |



IGPL L 型螺纹两通 Male elbow

| Model ( φD-T)          |            |            |
|------------------------|------------|------------|
| Tube(metric)-thread(R) |            |            |
| I GPL04-M5             | I GPL06-04 | I GPL10-03 |
| I GPL04-01             | I GPL08-01 | I GPL10-04 |
| I GPL04-02             | I GPL08-02 | I GPL12-01 |
| I GPL06-M5             | I GPL08-03 | I GPL12-02 |
| I GPL06-01             | I GPL08-04 | I GPL12-03 |
| I GPL06-02             | I GPL10-01 | I GPL12-04 |
| I GPL06-03             | I GPL10-02 |            |



IPB B 型螺纹三通 Male branch T

| Model ( φD-T)          |           |           |           |
|------------------------|-----------|-----------|-----------|
| Tube(metric)-thread(R) |           |           |           |
| I PB04-M5              | I PB06-04 | I PB10-03 | I PB16-03 |
| I PB04-01              | I PB08-01 | I PB10-04 | I PB16-04 |
| I PB04-02              | I PB08-02 | I PB12-01 |           |
| I PB06-M5              | I PB08-03 | I PB12-02 |           |
| I PB06-01              | I PB08-04 | I PB12-03 |           |
| I PB06-02              | I PB10-01 | I PB12-04 |           |
| I PB06-03              | I PB10-02 | I PB16-02 |           |



IPLL-G L 型加长螺纹两通 Extended male elbow

| Model ( φD-T)          |             |             |             |
|------------------------|-------------|-------------|-------------|
| Tube(metric)-thread(G) |             |             |             |
| I PLL04-M5             | I PLL06-G04 | I PLL10-G03 | I PLL16-G03 |
| I PLL04-G01            | I PLL08-G01 | I PLL10-G04 | I PLL16-G04 |
| I PLL04-G02            | I PLL08-G02 | I PLL12-G01 |             |
| I PLL06-M5             | I PLL08-G03 | I PLL12-G02 |             |
| I PLL06-G01            | I PLL08-G04 | I PLL12-G03 |             |
| I PLL06-G02            | I PLL10-G01 | I PLL12-G04 |             |
| I PLL06-G03            | I PLL10-G02 | I PLL16-G02 |             |



IGPL-G 型螺纹两通 Male elbow

| Model ( φD-T)          |             |             |
|------------------------|-------------|-------------|
| Tube(metric)-thread(G) |             |             |
| I GPL04-M5             | I GPL06-G04 | I GPL10-G03 |
| I GPL04-G01            | I GPL08-G01 | I GPL10-G04 |
| I GPL04-G02            | I GPL08-G02 | I GPL12-G01 |
| I GPL06-M5             | I GPL08-G03 | I GPL12-G02 |
| I GPL06-G01            | I GPL08-G04 | I GPL12-G03 |
| I GPL06-G02            | I GPL10-G01 | I GPL12-G04 |
| I GPL06-G03            | I GPL10-G02 |             |



IPB-G B 型螺纹三通 Male branch T

| Model ( φD-T)          |            |            |            |
|------------------------|------------|------------|------------|
| Tube(metric)-thread(G) |            |            |            |
| I PB04-M5              | I PB06-G04 | I PB10-G03 | I PB16-G03 |
| I PB04-G01             | I PB08-G01 | I PB10-G04 | I PB16-G04 |
| I PB04-G02             | I PB08-G02 | I PB12-G01 |            |
| I PB06-M5              | I PB08-G03 | I PB12-G02 |            |
| I PB06-G01             | I PB08-G04 | I PB12-G03 |            |
| I PB06-G02             | I PB10-G01 | I PB12-G04 |            |
| I PB06-G03             | I PB10-G02 |            |            |

快速接头 ONE-TOUCH FITTINGS



IPD D型螺纹三通 Male branch T

| Model ( φD-T)          |          |          |          |
|------------------------|----------|----------|----------|
| Tube(metric)-thread(R) |          |          |          |
| IPD04-M5               | IPD06-04 | IPD10-03 | IPD16-03 |
| IPD04-01               | IPD08-01 | IPD10-04 | IPD16-04 |
| IPD04-02               | IPD08-02 | IPD12-01 |          |
| IPD06-M5               | IPD08-03 | IPD12-02 |          |
| IPD06-01               | IPD08-04 | IPD12-03 |          |
| IPD06-02               | IPD10-01 | IPD12-04 |          |
| IPD06-03               | IPD10-02 | IPD16-02 |          |



IPX Y型螺纹三通 Male branch Y

| Model ( φD-T)          |          |          |          |
|------------------------|----------|----------|----------|
| Tube(metric)-thread(R) |          |          |          |
| IPX04-M5               | IPX06-04 | IPX10-03 | IPX16-03 |
| IPX04-01               | IPX08-01 | IPX10-04 | IPX16-04 |
| IPX04-02               | IPX08-02 | IPX12-01 |          |
| IPX06-M5               | IPX08-03 | IPX12-02 |          |
| IPX06-01               | IPX08-04 | IPX12-03 |          |
| IPX06-02               | IPX10-01 | IPX12-04 |          |
| IPX06-03               | IPX10-02 | IPX16-02 |          |



IPKD 螺纹五通 Male union

| Model ( φD-T)          |           |           |
|------------------------|-----------|-----------|
| Tube(metric)-thread(R) |           |           |
| IPKD04-M5              | IPKD06-04 | IPKD10-03 |
| IPKD04-01              | IPKD08-01 | IPKD10-04 |
| IPKD04-02              | IPKD08-02 | IPKD12-01 |
| IPKD06-M5              | IPKD08-03 | IPKD12-02 |
| IPKD06-01              | IPKD08-04 | IPKD12-03 |
| IPKD06-02              | IPKD10-01 | IPKD12-04 |
| IPKD06-03              | IPKD10-02 |           |



IPD-G D型螺纹三通 Male branch T

| Model ( φD-T)          |           |           |           |
|------------------------|-----------|-----------|-----------|
| Tube(metric)-thread(G) |           |           |           |
| IPD04-M5               | IPD06-G04 | IPD10-G03 | IPD16-G03 |
| IPD04-G01              | IPD08-G01 | IPD10-G04 | IPD16-G04 |
| IPD04-G02              | IPD08-G02 | IPD12-G01 |           |
| IPD06-M5               | IPD08-G03 | IPD12-G02 |           |
| IPD06-G01              | IPD08-G04 | IPD12-G03 |           |
| IPD06-G02              | IPD10-G01 | IPD12-G04 |           |
| IPD06-G03              | IPD10-G02 | IPD16-G02 |           |



IPX-G Y型螺纹三通 Male branch Y

| Model ( φD-T)          |           |           |           |
|------------------------|-----------|-----------|-----------|
| Tube(metric)-thread(G) |           |           |           |
| IPX04-M5               | IPX06-G04 | IPX10-G03 | IPX16-G03 |
| IPX04-G01              | IPX08-G01 | IPX10-G04 | IPX16-G04 |
| IPX04-G02              | IPX08-G02 | IPX12-G01 |           |
| IPX06-M5               | IPX08-G03 | IPX12-G02 |           |
| IPX06-G01              | IPX08-G04 | IPX12-G03 |           |
| IPX06-G02              | IPX10-G01 | IPX12-G04 |           |
| IPX06-G03              | IPX10-G02 | IPX16-G02 |           |



IPKD-G 螺纹五通 Male union

| Model ( φD-T)          |            |            |
|------------------------|------------|------------|
| Tube(metric)-thread(G) |            |            |
| IPKD04-M5              | IPKD06-G04 | IPKD10-G03 |
| IPKD04-G01             | IPKD08-G01 | IPKD10-G04 |
| IPKD04-G02             | IPKD08-G02 | IPKD12-G01 |
| IPKD06-M5              | IPKD08-G03 | IPKD12-G02 |
| IPKD06-G01             | IPKD08-G04 | IPKD12-G03 |
| IPKD06-G02             | IPKD10-G01 | IPKD12-G04 |
| IPKD06-G03             | IPKD10-G02 |            |

快速接头 ONE-TOUCH FITTINGS



IPH 外六角螺纹两通 Single universal elbow

| Model ( φD-T)          |          |          |
|------------------------|----------|----------|
| Tube(metric)-thread(R) |          |          |
| IPH04-M5               | IPH06-04 | IPH10-03 |
| IPH04-01               | IPH08-01 | IPH10-04 |
| IPH04-02               | IPH08-02 | IPH12-01 |
| IPH06-M5               | IPH08-03 | IPH12-02 |
| IPH06-01               | IPH08-04 | IPH12-03 |
| IPH06-02               | IPH10-01 | IPH12-04 |
| IPH06-03               | IPH10-02 |          |



IPHF 外六角内螺纹两通 Femal banjo

| Model ( φD-T)          |           |           |
|------------------------|-----------|-----------|
| Tube(metric)-thread(R) |           |           |
| IPHF04-M5              | IPHF06-04 | IPHF10-03 |
| IPHF04-01              | IPHF08-01 | IPHF10-04 |
| IPHF04-02              | IPHF08-02 | IPHF12-01 |
| IPHF06-M5              | IPHF08-03 | IPHF12-02 |
| IPHF06-01              | IPHF08-04 | IPHF12-03 |
| IPHF06-02              | IPHF10-01 | IPHF12-04 |
| IPHF06-03              | IPHF10-02 |           |



IPHL(2) 单头串联直角2 Double universal elbow

| Model ( φD-T)          |               |               |
|------------------------|---------------|---------------|
| Tube(metric)-thread(R) |               |               |
| IPHL(2) 04-M5          | IPHL(2) 06-04 | IPHL(2) 10-03 |
| IPHL(2) 04-01          | IPHL(2) 08-01 | IPHL(2) 10-04 |
| IPHL(2) 04-02          | IPHL(2) 08-02 | IPHL(2) 12-01 |
| IPHL(2) 06-M5          | IPHL(2) 08-03 | IPHL(2) 12-02 |
| IPHL(2) 06-01          | IPHL(2) 08-04 | IPHL(2) 12-03 |
| IPHL(2) 06-02          | IPHL(2) 10-01 | IPHL(2) 12-04 |
| IPHL(2) 06-03          | IPHL(2) 10-02 |               |



IPH-G 外六角螺纹两通 Single universal elbow

| Model ( φD-T)          |           |           |
|------------------------|-----------|-----------|
| Tube(metric)-thread(G) |           |           |
| IPH04-M5               | IPH06-G04 | IPH10-G03 |
| IPH04-G01              | IPH08-G01 | IPH10-G04 |
| IPH04-G02              | IPH08-G02 | IPH12-G01 |
| IPH06-M5               | IPH08-G03 | IPH12-G02 |
| IPH06-G01              | IPH08-G04 | IPH12-G03 |
| IPH06-G02              | IPH10-G01 | IPH12-G04 |
| IPH06-G03              | IPH10-G02 |           |



IPGJ 变径直通插头 Increase U

| Model ( φD1-D2) |
|-----------------|
| Tube(metric)    |
| IPGJ06-04       |
| IPGJ08-06       |
| IPGJ10-08       |
| IPGJ12-10       |



IPHL(2)-G 单头串联直角2 Double universal elbow

| Model ( φD-T)          |                |                |
|------------------------|----------------|----------------|
| Tube(metric)-thread(G) |                |                |
| IPHL(2) 04-M5          | IPHL(2) 06-G04 | IPHL(2) 10-G03 |
| IPHL(2) 04-G01         | IPHL(2) 08-G01 | IPHL(2) 10-G04 |
| IPHL(2) 04-G02         | IPHL(2) 08-G02 | IPHL(2) 12-G01 |
| IPHL(2) 06-M5          | IPHL(2) 08-G03 | IPHL(2) 12-G02 |
| IPHL(2) 06-G01         | IPHL(2) 08-G04 | IPHL(2) 12-G03 |
| IPHL(2) 06-G02         | IPHL(2) 10-G01 | IPHL(2) 12-G04 |
| IPHL(2) 06-G03         | IPHL(2) 10-G02 |                |

快速接头 ONE-TOUCH FITTINGS



IPHL(3) 单头串联直角 3 Triple universal elbow

| Model ( φD-T)          |              |              |
|------------------------|--------------|--------------|
| Tube(metric)-thread(R) |              |              |
| IPHL(3)04-M5           | IPHL(3)06-04 | IPHL(3)10-03 |
| IPHL(3)04-01           | IPHL(3)08-01 | IPHL(3)10-04 |
| IPHL(3)04-02           | IPHL(3)08-02 | IPHL(3)12-01 |
| IPHL(3)06-M5           | IPHL(3)08-03 | IPHL(3)12-02 |
| IPHL(3)06-01           | IPHL(3)08-04 | IPHL(3)12-03 |
| IPHL(3)06-02           | IPHL(3)10-01 | IPHL(3)12-04 |
| IPHL(3)06-03           | IPHL(3)10-02 |              |



IPLJ L型等径插头 Blance L

| Model ( φD1-D2) |  |
|-----------------|--|
| Tube(metric)    |  |
| IPLJ04          |  |
| IPLJ06          |  |
| IPLJ08          |  |
| IPLJ10          |  |
| IPLJ12          |  |
| IPLJ16          |  |



IPDJ D型等径插头 Blance D

| Model ( φD1-D2) |  |
|-----------------|--|
| Tube(metric)    |  |
| IPDJ04          |  |
| IPDJ06          |  |
| IPDJ08          |  |
| IPDJ10          |  |
| IPDJ12          |  |
| IPDJ16          |  |



IPHL(3)-G 单头串联直角 3 Triple universal elbow

| Model ( φD-T)          |               |               |
|------------------------|---------------|---------------|
| Tube(metric)-thread(G) |               |               |
| IPHL(3)04-M5           | IPHL(3)06-G04 | IPHL(3)10-G03 |
| IPHL(3)04-G01          | IPHL(3)08-G01 | IPHL(3)10-G04 |
| IPHL(3)04-G02          | IPHL(3)08-G02 | IPHL(3)12-G01 |
| IPHL(3)06-M5           | IPHL(3)08-G03 | IPHL(3)12-G02 |
| IPHL(3)06-G01          | IPHL(3)08-G04 | IPHL(3)12-G03 |
| IPHL(3)06-G02          | IPHL(3)10-G01 | IPHL(3)12-G04 |
| IPHL(3)06-G03          | IPHL(3)10-G02 |               |



IPBJ(PEWJ,PEGJ) B型插头 Balance/increase B

| Model ( φD1-D2) |            |            |
|-----------------|------------|------------|
| Tube(metric)    |            |            |
| IPBJ            | IPEWJ      | IPEGJ      |
| IPBJ04          | IPEWJ06-04 | IPEGJ04-06 |
| IPBJ06          | IPEWJ08-06 | IPEGJ06-08 |
| IPBJ08          | IPEWJ10-08 | IPEGJ08-10 |
| IPBJ10          | IPEWJ12-10 | IPEGJ10-12 |
| IPBJ12          | IPEWJ16-12 | IPEGJ12-16 |
| IPBJ16          |            |            |



IPYJ(PWJ) Y型插头 Balance/increase Y

| Model ( φD1-D2) |           |
|-----------------|-----------|
| Tube(metric)    |           |
| IPYJ            | IPWJ      |
| IPYJ04          | IPWJ06-04 |
| IPYJ06          | IPWJ08-06 |
| IPYJ08          | IPWJ10-08 |
| IPYJ10          | IPWJ12-10 |
| IPYJ12          | IPWJ16-12 |
| IPYJ16          |           |

快速接头 ONE-TOUCH FITTINGS



IPU U型塑料三通 Union U

| Model ( φD)  |  |
|--------------|--|
| Tube(metric) |  |
| I PU04       |  |
| I PU06       |  |
| I PU18       |  |
| I PU10       |  |
| I PU12       |  |
| I PU16       |  |



IPE T型塑料三通 Union E

| Model ( φD)  |  |
|--------------|--|
| Tube(metric) |  |
| I PE04       |  |
| I PE06       |  |
| I PE18       |  |
| I PE10       |  |
| I PE12       |  |
| I PE16       |  |



IPG U型减径塑料三通 Reduce union U

| Model ( φD1-D2) |           |
|-----------------|-----------|
| Tube(metric)    |           |
| I PG06-04       |           |
| I PG08-06       | I PG08-04 |
| I PG10-08       | I PG10-06 |
| I PG12-10       | I PG12-08 |
| I PG16-12       | I PG16-10 |



IPV L型塑料三通 Union L

| Model ( φD)  |  |
|--------------|--|
| Tube(metric) |  |
| IPV04        |  |
| IPV06        |  |
| IPV18        |  |
| IPV10        |  |
| IPV12        |  |
| IPV16        |  |



IPY Y型塑料三通 Union Y

| Model ( φD)  |  |
|--------------|--|
| Tube(metric) |  |
| IPY04        |  |
| IPY06        |  |
| IPY18        |  |
| IPY10        |  |
| IPY12        |  |
| IPY16        |  |



IPW Y型减径塑料三通 Reduce union Y

| Model ( φD1-D2) |  |
|-----------------|--|
| Tube(metric)    |  |
| IPW06-04        |  |
| IPW08-06        |  |
| IPW10-08        |  |
| IPW12-10        |  |
| IPW16-12        |  |

快速接头 ONE-TOUCH FITTINGS



IPEG 变径塑料三通 G Reduce 1

| Model ( $\phi$ D1-D2) |
|-----------------------|
| Tube(metric)          |
| IPEG06-04             |
| IPEG08-06             |
| IPEG10-08             |
| IPEG12-10             |
| IPEG16-12             |



IPZA X型塑料四通 Union Z

| Model ( $\phi$ D) |
|-------------------|
| Tube(metric)      |
| IPZA04            |
| IPZA06            |
| IPZA08            |
| IPZA10            |
| IPZA12            |



IPK 塑料五通 Union K

| Model ( $\phi$ D) |
|-------------------|
| Tube(metric)      |
| IPK04             |
| IPK06             |
| IPK08             |
| IPK10             |
| IPK12             |



IPEW 变径塑料三通 W Reduce 2

| Model ( $\phi$ D1-D2) |
|-----------------------|
| Tube(metric)          |
| IPEW06-04             |
| IPEW08-06             |
| IPEW10-08             |
| IPEW12-10             |
| IPEW16-12             |



IPP 管塞 Plug

| Model ( $\phi$ D) |
|-------------------|
| Tube(metric)      |
| IPP04             |
| IPP06             |
| IPP08             |
| IPP10             |
| IPP12             |
| IPP16             |



IPKG 变径塑料五通 Reduce union K

| Model ( $\phi$ D1-D2) |
|-----------------------|
| Tube(metric)          |
| IPKG06-04             |
| IPKG08-06             |
| IPKG10-08             |
| IPKG12-10             |

快速接头 ONE-TOUCH FITTINGS



IPIJ 等径塑料直通 Tube spicer

| Model ( $\phi$ D) |
|-------------------|
| Tube(metric)      |
| IPIJ04            |
| IPIJ06            |
| IPIJ08            |
| IPIJ10            |
| IPIJ12            |
| IPIJ16            |



IPIG 减径塑料直通 Reducer tube spicer

| Model ( $\phi$ D1-D2) |
|-----------------------|
| Tube(metric)          |
| IPIG06-04             |
| IPIG08-06             |
| IPIG10-08             |
| IPIG12-10             |
| IPIG16-12             |



## 调速节流阀 SPEED CONTROLLERS

### 特点 Features

控制空气流量的阀，又称调速阀。  
改良成小型化，所以装在设备上所占体积很小。  
流量控制从小到大，可以进行微量调节。

### 使用范围说明 Specifications

|        |                                 |                                     |
|--------|---------------------------------|-------------------------------------|
| 使用流体   | Air (No other gases or liquids) |                                     |
| 使用压力   | 0~150PSI                        | 0~10Kgf/cm <sup>2</sup> (0~1000kPa) |
| 负压     | 7.5PSI                          | 0.5Kgf/cm <sup>2</sup> (50kPa)      |
| 使用温度范围 | 32~140° F                       | -10~60°C                            |
| 使用气管种类 | Polyurethane and nylon          |                                     |



### 产品标志形色 Product code system



|      | Metric size |    |    |    |     |     | Inch size |       |       |      |       |      |      |
|------|-------------|----|----|----|-----|-----|-----------|-------|-------|------|-------|------|------|
| Code | 03          | 04 | 06 | 08 | 10  | 12  | 1/8       | 5/32  | 3/16  | 1/4  | 5/16  | 3/8  | 1/2  |
| Dia  | φ3          | φ4 | φ6 | φ8 | φ10 | φ12 | φ1/8      | φ5/32 | φ3/16 | φ1/4 | φ5/16 | φ3/8 | φ1/2 |

### 3 螺纹规格

| Code | Metric thread & R (PT) thread |                                     |
|------|-------------------------------|-------------------------------------|
|      | Metric size                   | American standard taper pipe thread |
| Size | M3<br>M3x0.5                  | M5<br>M5x0.8                        |
|      | R1/8                          | R1/4                                |
|      | R3/8                          | R1/2                                |

| Code | Inch thread (NUF & NPT) |                                     |        |        |        |
|------|-------------------------|-------------------------------------|--------|--------|--------|
|      | Unified fine thread     | American standard taper pipe thread |        |        |        |
| Size | 10~32UNF                | NPT1/8                              | NPT1/4 | NPT3/8 | NPT1/2 |

### 4 控制方式

| Type   | Meter out | Meter in |
|--------|-----------|----------|
| Sleeve | SL08-02   | SL08-02B |
|        | Blue      | Black    |
|        |           | Red      |
|        |           | Red      |

### 结构图 Structural diagram

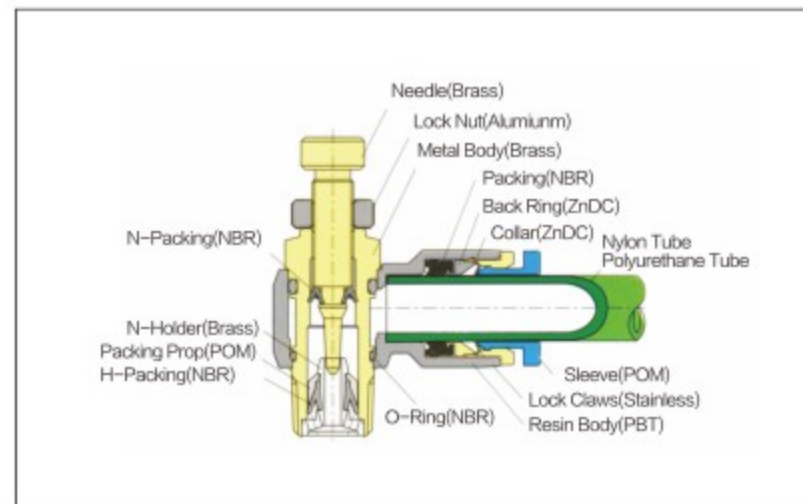

## 调速节流阀 SPEED CONTROLLERS



SC(B) 节流阀 Swivel rotating

| Model ( φ D-T)         |         |         |
|------------------------|---------|---------|
| Tube(metric)-thread(R) |         |         |
| SC04-M5                | SC06-04 | SC10-03 |
| SC04-01                | SC08-01 | SC10-04 |
| SC04-02                | SC08-02 | SC12-01 |
| SC06-M5                | SC08-03 | SC12-02 |
| SC06-01                | SC08-04 | SC12-03 |
| SC06-02                | SC10-01 | SC12-04 |
| SC06-03                | SC10-02 |         |



SC(B)-DC D型节流阀 Swivel rotating D

| Model ( φ D-T)         |            |            |
|------------------------|------------|------------|
| Tube(metric)-thread(R) |            |            |
| SC04-M5-DC             | SC06-04-DC | SC10-03-DC |
| SC04-01-DC             | SC08-01-DC | SC10-04-DC |
| SC04-02-DC             | SC08-02-DC | SC12-01-DC |
| SC06-M5-DC             | SC08-03-DC | SC12-02-DC |
| SC06-01-DC             | SC08-04-DC | SC12-03-DC |
| SC06-02-DC             | SC10-01-DC | SC12-04-DC |
| SC06-03-DC             | SC10-02-DC |            |



SA 管道阀 Union straight

| Model ( φ D) |      |
|--------------|------|
| Tube(metric) |      |
|              | SA04 |
|              | SA06 |
|              | SA08 |
|              | SA10 |
|              | SA12 |



SC(B)-G 节流阀 Swivel rotating

| Model ( φ D-T)         |          |          |
|------------------------|----------|----------|
| Tube(metric)-thread(G) |          |          |
| SC04-M5                | SC06-G04 | SC10-G03 |
| SC04-G01               | SC08-G01 | SC10-G04 |
| SC04-G02               | SC08-G02 | SC12-G01 |
| SC06-M5                | SC08-G03 | SC12-G02 |
| SC06-G01               | SC08-G04 | SC12-G03 |
| SC06-G02               | SC10-G01 | SC12-G04 |
| SC06-G03               | SC10-G02 |          |



SC(B)-DC-G D型节流阀 Swivel rotating D

| Model ( φ D-T)         |             |             |
|------------------------|-------------|-------------|
| Tube(metric)-thread(G) |             |             |
| SC04-M5-DC             | SC06-G04-DC | SC10-G03-DC |
| SC04-G01-DC            | SC08-G01-DC | SC10-G04-DC |
| SC04-G02-DC            | SC08-G02-DC | SC12-G01-DC |
| SC06-M5-DC             | SC08-G03-DC | SC12-G02-DC |
| SC06-G01-DC            | SC08-G04-DC | SC12-G03-DC |
| SC06-G02-DC            | SC10-G01-DC | SC12-G04-DC |
| SC06-G03-DC            | SC10-G02-DC |             |

## 手阀 HAND VALVES

### 特点 Features

手阀用于开关压缩空气  
二通阀及三通阀可供选  
三通阀关闭时排出设备残余气体  
多种规格和安装简单, 使用方便



### 使用范围说明 Specifications

|        |                                 |                                     |
|--------|---------------------------------|-------------------------------------|
| 使用流体   | Air (No other gases or liquids) |                                     |
| 使用压力   | 0~150PSI                        | 0~10Kgf/cm <sup>2</sup> (0~1000kPa) |
| 负压     | -29.5in Hg                      | -750mm Hg (10Torr)                  |
| 使用温度范围 | 32~140° F                       | -10~60°C                            |
| 使用气管种类 | Polyurethane and nylon          |                                     |

### 产品标志形色 Product code system



①型号  
②管径大小 (φD)

|      | Metric size |    |     |     |
|------|-------------|----|-----|-----|
| Code | 06          | 08 | 10  | 12  |
| Dia  | φ6          | φ8 | φ10 | φ12 |

③螺纹规格

| Code | Metric thread & R (PT) thread |      |      |      |
|------|-------------------------------|------|------|------|
|      | Taper pipe thread             |      |      |      |
| Size | 01                            | 02   | 03   | 04   |
|      | R1/8                          | R1/4 | R3/8 | R1/2 |

### 结构图 Structural diagram

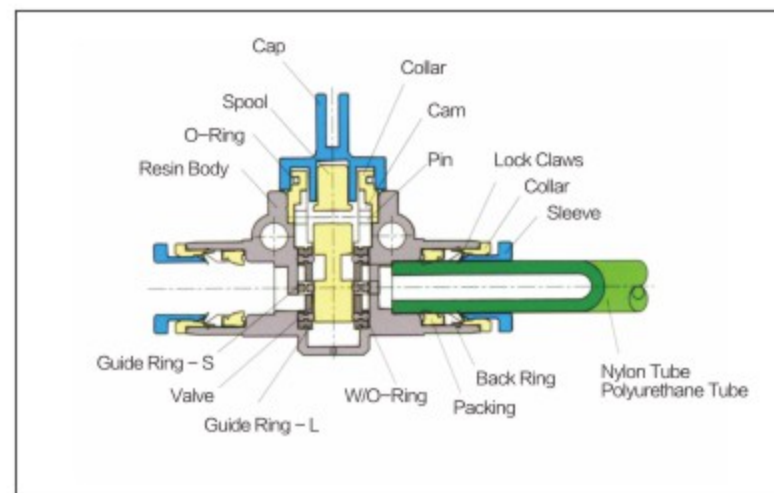

## 手阀 HAND VALVES



HVFF 插管 - 插管 Nipple

| Model (φD)   |           |
|--------------|-----------|
| Tube(metric) |           |
|              | HVFF06-06 |
|              | HVFF08-08 |
|              | HVFF10-10 |
|              | HVFF12-12 |



HVFS 插管 - 螺纹 Straight A

| Model (φD-T)           |           |  |
|------------------------|-----------|--|
| Tube(metric)-thread(R) |           |  |
| HVFS06-01              | HVFS10-03 |  |
| HVFS06-02              | HVFS10-04 |  |
| HVFS06-03              | HVFS12-02 |  |
| HVFS08-01              | HVFS12-03 |  |
| HVFS08-02              | HVFS12-04 |  |
| HVFS08-03              |           |  |
| HVFS10-02              |           |  |



HVSF 螺纹 - 插管 Straight B

| Model (T-φD)           |           |
|------------------------|-----------|
| Tube(metric)-thread(R) |           |
| HVSF01-06              | HVSF03-10 |
| HVSF02-06              | HVSF04-10 |
| HVSF03-06              | HVSF02-12 |
| HVSF01-08              | HVSF03-12 |
| HVSF02-08              | HVSF04-12 |
| HVSF03-08              |           |
| HVSF02-10              |           |



HVSS 螺纹 - 螺纹 Nipple

| Model (φD-T) |           |
|--------------|-----------|
| Thread(R)    |           |
|              | HVSS01-01 |
|              | HVSS02-01 |
|              | HVSS02-02 |
|              | HVSS03-02 |
|              | HVSS03-03 |
|              | HVSS04-03 |

## 截止阀 STOP FITTINGS

### 特点 Features

截止阀接头在连接管子时可以双流通气体，  
如果拔出管子就截止空气流通，  
可以保证机械维修时的安全。  
截止阀接头只有在插进管子才通压缩空气。

### 使用范围说明 Specifications

|        |                                 |                                     |
|--------|---------------------------------|-------------------------------------|
| 使用流体   | Air (No other gases or liquids) |                                     |
| 使用压力   | 0~150PSI                        | 0~10Kgf/cm <sup>2</sup> (0~1000kPa) |
| 使用温度范围 | 32~140° F                       | -10~60°C                            |
| 使用气管种类 | Polyurethane and nylon          |                                     |



### 产品标志形色 Product code system



①型号  
②管径大小 (φD)

| Code | Metric size |    |    |     |     | Inch size |       |      |       |      |      |
|------|-------------|----|----|-----|-----|-----------|-------|------|-------|------|------|
|      | 04          | 06 | 08 | 10  | 12  | 5/32      | 3/16  | 1/4  | 5/16  | 3/8  | 1/2  |
| Dia  | φ4          | φ6 | φ8 | φ10 | φ12 | φ5/32     | φ3/16 | φ1/4 | φ5/16 | φ3/8 | φ1/2 |

③螺纹规格

| *Metric thread & R (PT) thread |             |        |      |                   |      |      |
|--------------------------------|-------------|--------|------|-------------------|------|------|
| Code                           | Metric size |        |      | Taper pipe thread |      |      |
|                                | Size        | M5     | M6   | 01                | 02   | 03   |
|                                | M5x0.8      | M6x1.0 | R1/8 | R1/4              | R3/8 | R1/2 |

| *Inch thread (NUF & NPT) |                     |        |                                     |        |        |
|--------------------------|---------------------|--------|-------------------------------------|--------|--------|
| Code                     | Unified fine thread |        | American standard taper pipe thread |        |        |
|                          | Size                | U10U   | N01U                                | N02U   | N03U   |
|                          | 10-32UNF            | NPT1/8 | NPT1/4                              | NPT3/8 | NPT1/2 |

### 结构图 Structural diagram

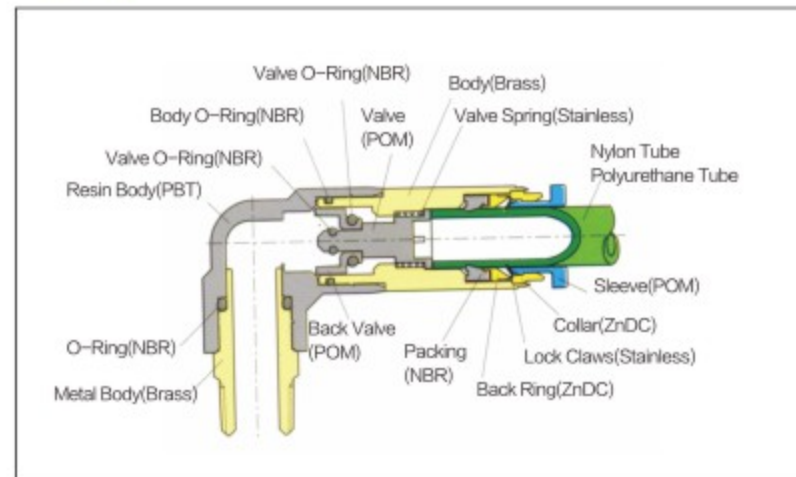

## 截止阀 STOP FITTINGS



SPC 直通截止阀 Straight

| Model (φD-T)           |          |          |          |
|------------------------|----------|----------|----------|
| Tube(metric)-thread(R) |          |          |          |
| SPC04-M5               | SPC06-04 | SPC10-03 | SPC16-03 |
| SPC04-01               | SPC08-01 | SPC10-04 | SPC16-04 |
| SPC04-02               | SPC08-02 | SPC12-01 |          |
| SPC06-M5               | SPC08-03 | SPC12-02 |          |
| SPC06-01               | SPC08-04 | SPC12-03 |          |
| SPC06-02               | SPC10-01 | SPC12-04 |          |
| SPC06-03               | SPC10-02 | SPC16-02 |          |



SPL L型截止阀 Elbow

| Model (φD-T)           |          |          |          |
|------------------------|----------|----------|----------|
| Tube(metric)-thread(R) |          |          |          |
| SPL04-M5               | SPL06-04 | SPL10-03 | SPL16-03 |
| SPL04-01               | SPL08-01 | SPL10-04 | SPL16-04 |
| SPL04-02               | SPL08-02 | SPL12-01 |          |
| SPL06-M5               | SPL08-03 | SPL12-02 |          |
| SPL06-01               | SPL08-04 | SPL12-03 |          |
| SPL06-02               | SPL10-01 | SPL12-04 |          |
| SPL06-03               | SPL10-02 | SPL16-02 |          |



SPM 隔板截止阀 Union straight

| Model (φD)   |  |
|--------------|--|
| Tube(metric) |  |
| SPM04        |  |
| SPM06        |  |
| SPM08        |  |
| SPM10        |  |
| SPM12        |  |
| SPM16        |  |



SPC-G 直通截止阀 Straight

| Model (φD-T)           |           |           |           |
|------------------------|-----------|-----------|-----------|
| Tube(metric)-thread(G) |           |           |           |
| SPC04-M5               | SPC06-G04 | SPC10-G03 | SPC16-G03 |
| SPC04-G01              | SPC08-G01 | SPC10-G04 | SPC16-G04 |
| SPC04-G02              | SPC08-G02 | SPC12-G01 |           |
| SPC06-M5               | SPC08-G03 | SPC12-G02 |           |
| SPC06-G01              | SPC08-G04 | SPC12-G03 |           |
| SPC06-G02              | SPC10-G01 | SPC12-G04 |           |
| SPC06-G03              | SPC10-G02 | SPC16-G02 |           |



SPL-G L型截止阀 Elbow

| Model (φD-T)           |           |           |           |
|------------------------|-----------|-----------|-----------|
| Tube(metric)-thread(G) |           |           |           |
| SPL04-M5               | SPL06-G04 | SPL10-G03 | SPL16-G03 |
| SPL04-G01              | SPL08-G01 | SPL10-G04 | SPL16-G04 |
| SPL04-G02              | SPL08-G02 | SPL12-G01 |           |
| SPL06-M5               | SPL08-G03 | SPL12-G02 |           |
| SPL06-G01              | SPL08-G04 | SPL12-G03 |           |
| SPL06-G02              | SPL10-G01 | SPL12-G04 |           |
| SPL06-G03              | SPL10-G02 | SPL16-G02 |           |



SPU 两通截止阀 Union straight

| Model (φD)   |  |
|--------------|--|
| Tube(metric) |  |
| SPU04        |  |
| SPU06        |  |
| SPU08        |  |
| SPU10        |  |
| SPU12        |  |
| SPU16        |  |

## 单向阀 CHECK VALVES

### 特点 Features

单向阀指单方向流动空气，阻断逆方向的流动。  
单向阀在 0.1Kg/cm<sup>2</sup> 压力时启动。  
单向阀在真空可维持 1.42PSI，所以在低压状态下可连接使用。

### 使用范围说明 Specifications

|        |                                 |                                    |
|--------|---------------------------------|------------------------------------|
| 使用流体   | Air (No other gases or liquids) |                                    |
| 使用压力   | 0-150PSI                        | 0-10Kg/cm <sup>2</sup> (0-1000kPa) |
| 负压     | -29.5in Hg                      | -750mm Hg (10Torr)                 |
| 使用温度范围 | 32-140° F                       | -10-60°C                           |
| 使用气嘴种类 | Polyurethane and nylon          |                                    |

### 产品标志形色 Product code system



①型号  
②管径大小 (φD)

| Code | Metric size |    |    |     |     | Inch size |       |      |       |      |      |
|------|-------------|----|----|-----|-----|-----------|-------|------|-------|------|------|
|      | 04          | 06 | 08 | 10  | 12  | 5/32      | 3/16  | 1/4  | 5/16  | 3/8  | 1/2  |
| Dia  | φ4          | φ6 | φ8 | φ10 | φ12 | φ5/32     | φ3/16 | φ1/4 | φ5/16 | φ3/8 | φ1/2 |

③螺纹规格

| Code | Metric size |        |        | Taper pipe thread |      |      |      |
|------|-------------|--------|--------|-------------------|------|------|------|
|      | Size        | M5x0.8 | M6x1.0 | R1/8              | R1/4 | R3/8 | R1/2 |

| Code | Unified fine thread |      | American standard taper pipe thread |      |      |      |
|------|---------------------|------|-------------------------------------|------|------|------|
|      | Size                | U10U | N01U                                | N02U | N03U | N04U |

### 结构图 Structural diagram

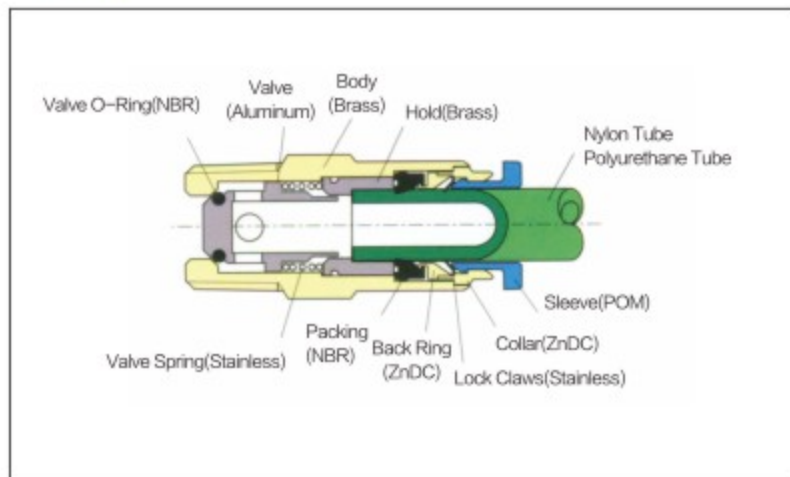

## 单向阀 CHECK VALVES



CVPC 直通单向阀 Straight

| Model ( φD-T)          |           |           |           |
|------------------------|-----------|-----------|-----------|
| Tube(metric)-thread(R) |           |           |           |
| CVPC04-M5              | CVPC06-04 | CVPC10-03 | CVPC16-03 |
| CVPC04-01              | CVPC08-01 | CVPC10-04 | CVPC16-04 |
| CVPC04-02              | CVPC08-02 | CVPC12-01 |           |
| CVPC06-M5              | CVPC08-03 | CVPC12-02 |           |
| CVPC06-01              | CVPC08-04 | CVPC12-03 |           |
| CVPC06-02              | CVPC10-01 | CVPC12-04 |           |
| CVPC06-03              | CVPC10-02 | CVPC16-02 |           |



CVPL L型单向阀 Elbow

| Model ( φD-T)          |           |           |           |
|------------------------|-----------|-----------|-----------|
| Tube(metric)-thread(R) |           |           |           |
| CVPL04-M5              | CVPL06-04 | CVPL10-03 | CVPL16-03 |
| CVPL04-01              | CVPL08-01 | CVPL10-04 | CVPL16-04 |
| CVPL04-02              | CVPL08-02 | CVPL12-01 |           |
| CVPL06-M5              | CVPL08-03 | CVPL12-02 |           |
| CVPL06-01              | CVPL08-04 | CVPL12-03 |           |
| CVPL06-02              | CVPL10-01 | CVPL12-04 |           |
| CVPL06-03              | CVPL10-02 | CVPL16-02 |           |



CVPM 隔板单向阀 Union straight

| Model ( φD)  |        |
|--------------|--------|
| Tube(metric) |        |
|              | CVPM04 |
|              | CVPM06 |
|              | CVPM08 |
|              | CVPM10 |
|              | CVPM12 |
|              | CVPM16 |



CVPC-G 直通单向阀 Straight

| Model ( φD-T)          |            |            |            |
|------------------------|------------|------------|------------|
| Tube(metric)-thread(G) |            |            |            |
| CVPC04-M5              | CVPC06-G04 | CVPC10-G03 | CVPC16-G03 |
| CVPC04-G01             | CVPC08-G01 | CVPC10-G04 | CVPC16-G04 |
| CVPC04-G02             | CVPC08-G02 | CVPC12-G01 |            |
| CVPC06-M5              | CVPC08-G03 | CVPC12-G02 |            |
| CVPC06-G01             | CVPC08-G04 | CVPC12-G03 |            |
| CVPC06-G02             | CVPC10-G01 | CVPC12-G04 |            |
| CVPC06-G03             | CVPC10-G02 | CVPC16-G02 |            |



CVPL-G L型单向阀 Elbow

| Model ( φD-T)          |            |            |            |
|------------------------|------------|------------|------------|
| Tube(metric)-thread(G) |            |            |            |
| CVPL04-M5              | CVPL06-G04 | CVPL10-G03 | CVPL16-G03 |
| CVPL04-G01             | CVPL08-G01 | CVPL10-G04 | CVPL16-G04 |
| CVPL04-G02             | CVPL08-G02 | CVPL12-G01 |            |
| CVPL06-M5              | CVPL08-G03 | CVPL12-G02 |            |
| CVPL06-G01             | CVPL08-G04 | CVPL12-G03 |            |
| CVPL06-G02             | CVPL10-G01 | CVPL12-G04 |            |
| CVPL06-G03             | CVPL10-G02 | CVPL16-G02 |            |



CVPU 两通单向阀 Union straight

| Model ( φD)  |        |
|--------------|--------|
| Tube(metric) |        |
|              | CVPU04 |
|              | CVPU06 |
|              | CVPU08 |
|              | CVPU10 |
|              | CVPU12 |
|              | CVPU16 |

## 迷你接头 COMPACT ONE-TOUCH FITTINGS

### 特点 Features

超小型产品 (COMPACT), 比普通型号体积小 40%, 外形尺寸小 20%, 是小型化的 ONE-TOUCH FITTINGS。  
由于表面有镀铬处理, 所以耐腐蚀性突出。

### 使用范围说明 Specifications

|        |                                 |                                     |
|--------|---------------------------------|-------------------------------------|
| 使用流体   | Air (No other gases or liquids) |                                     |
| 使用压力   | 0-150PSI                        | 0-10Kgf/cm <sup>2</sup> (0-1000kPa) |
| 负压     | -29.5 in Hg                     | -750mmHg (10Torr)                   |
| 使用温度范围 | 32-140° F                       | -10-60°C                            |
| 使用气管种类 | Polyurethane and nylon          |                                     |

### 产品标志形色 Product code system



①型号  
②管径大小 (D)

| Code | Metric size |    |    | Inch size |       |      |
|------|-------------|----|----|-----------|-------|------|
|      | 03          | 04 | 06 | 1/8       | 5/32  | 1/4  |
| Dia  | φ4          | φ4 | φ6 | φ1/8      | φ5/32 | φ1/4 |

③螺纹规格

| *Metric thread & R (PT) thread |             |        |        |      |
|--------------------------------|-------------|--------|--------|------|
| Code                           | Metric size |        |        |      |
|                                | Size        | M3     | M5     | M6   |
|                                | M3x0.5      | M5x0.8 | M6x1.0 | R1/8 |

| *Inch thread (NUF & NPT) |                     |                                     |
|--------------------------|---------------------|-------------------------------------|
| Code                     | Unified fine thread | American standard taper pipe thread |
|                          | Size                | U10U                                |
|                          | 10-32UNF            | NPT1/16 NPT1/8                      |

④迷你接头

### 结构图 Structural diagram

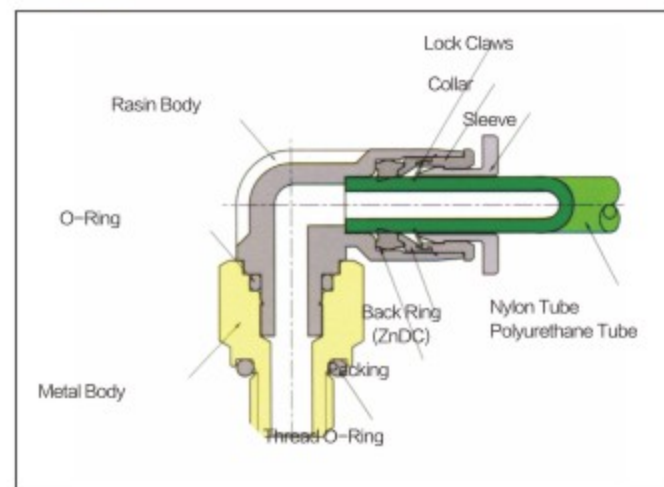

## 迷你接头 COMPACT ONE-TOUCH FITTINGS



PC-C 螺纹直通 Male straight

| Model (φD-T)           |          |
|------------------------|----------|
| Tube(metric)-thread(R) |          |
| PC03-M3C               | PC06-M3C |
| PC03-M5C               | PC06-M5C |
| PC03-M6C               | PC06-M6C |
| PC04-M3C               | PC06-01C |
| PC04-M5C               |          |
| PC04-M6C               |          |
| PC04-01C               |          |



POC-C 螺纹圆形直通 Round Male straight

| Model (φD-T)           |           |
|------------------------|-----------|
| Tube(metric)-thread(R) |           |
| POC03-M3C              | POC06-M3C |
| POC03-M5C              | POC06-M5C |
| POC03-M6C              | POC06-M6C |
| POC04-M3C              | POC06-01C |
| POC04-M5C              |           |
| POC04-M6C              |           |
| POC04-01C              |           |



PL-C L型螺纹两通 Male elbow

| Model (φD-T)           |          |
|------------------------|----------|
| Tube(metric)-thread(R) |          |
| PL03-M3C               | PL06-M3C |
| PL03-M5C               | PL06-M5C |
| PL03-M6C               | PL06-M6C |
| PL04-M3C               | PL06-01C |
| PL04-M5C               |          |
| PL04-M6C               |          |
| PL04-01C               |          |



PLL-C L型加长螺纹两通 Extended male elbow

| Model (φD-T)           |           |
|------------------------|-----------|
| Tube(metric)-thread(R) |           |
| PLL03-M3C              | PLL06-M3C |
| PLL03-M5C              | PLL06-M5C |
| PLL03-M6C              | PLL06-M6C |
| PLL04-M3C              | PLL06-01C |
| PLL04-M5C              |           |
| PLL04-M6C              |           |
| PLL04-01C              |           |



PM-C 隔板两通 Bulkhead union

| Model (φD)   |  |
|--------------|--|
| Tube(metric) |  |
| PM03C        |  |
| PM04C        |  |
| PM06C        |  |



PLM-C L型隔板两通 Bulkhead union L

| Model (φD)   |  |
|--------------|--|
| Tube(metric) |  |
| PLM03C       |  |
| PLM04C       |  |
| PLM06C       |  |

迷你接头 COMPACT ONE-TOUCH FITTINGS



PU-C 塑料两通 Union U

| Model (φD)   |
|--------------|
| Tube(metric) |
| PU03C        |
| PU04C        |
| PU06C        |



PV-C L型塑料两通 Union L

| Model (φD)   |
|--------------|
| Tube(metric) |
| PV03C        |
| PV04C        |
| PV06C        |



PE-C L型塑料三通 Union T

| Model (φD)   |
|--------------|
| Tube(metric) |
| PE03C        |
| PE04C        |
| PE06C        |



PY-C Y型塑料两通 Union Y

| Model (φD)   |
|--------------|
| Tube(metric) |
| PY03C        |
| PY04C        |
| PY06C        |

消声器 SLIENCERS



PSL 塑料消声器 Silencers

| Model(T)  |
|-----------|
| Thread(R) |
| PSL01     |
| PSL02     |
| PSL03     |
| PSL04     |
| PSL06     |
| PSL10     |



PSU 塑料消声器 Silencers

| Model(T)  |
|-----------|
| Thread(R) |
| PSU01     |
| PSU02     |
| PSU03     |
| PSU04     |
| PSU06     |
| PSU10     |



BSL 全铜消声器 Metal

| Model(T)  |
|-----------|
| Thread(R) |
| BSL01     |
| BSL02     |
| BSL03     |
| BSL04     |
| BSL06     |
| BSL10     |



BSLM 全铜消声器 Metal

| Model(T)  |
|-----------|
| Thread(R) |
| BSLM01    |
| BSLM02    |
| BSLM03    |
| BSLM04    |
| BSLM06    |
| BSLM10    |



BESL 全铜消声器 Metal

| Model(T)  |
|-----------|
| Thread(R) |
| BESL01    |
| BESL02    |
| BESL03    |
| BESL04    |
| BESL06    |
| BESL10    |



堵头 Plug

| Model (T)   |     |
|-------------|-----|
| Thread(R/G) |     |
| 01          | G01 |
| 02          | G02 |
| 03          | G03 |
| 04          | G04 |
| 06          | G06 |
| 10          | G10 |

插入式 FCR 系列气管接头(全铜镀镍)  
FCR Series metal push-in fittings(brass & nickle-plate)

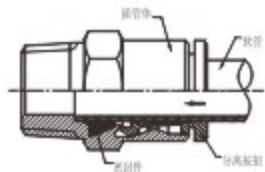

FCR-终端接头 FCR-Male stud

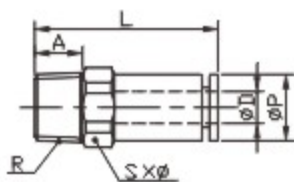

FCR-A 圆柱形终端接头  
FCR-A Round body male stud

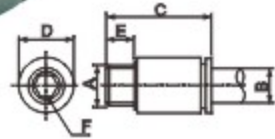

FCR-B 内螺纹接头 FCR-B Female stud

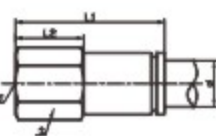

FCR-S 直通穿板接头 FCR-S Bulkhead union

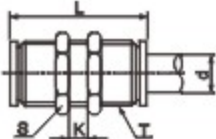

插入式管接头可与PA, PU, PE软管配合使用在压缩气回路。连接气缸、气阀及气动逻辑元件等。  
全黄铜制造, 镀镍处理, 采用新结构密封圈, 工作压力可达1.6MPa, 体积小, 造型美观, 拆装快捷, 使气动系统大大简化。用户如需其它规格, 请订货时说明。  
Connection and disconnection of the tube can be repeated several times and is performed with one hand, without the use of tools. The sealing ring(O-ring) can be easily replaced if it is damaged. If user needs other specifications of thread, please state clearly when ordering.

| 型号 d (mm)<br>Model | T(牙径)     | S  | L <sub>1</sub> | L <sub>2</sub> | 订货号<br>Order no. |
|--------------------|-----------|----|----------------|----------------|------------------|
| FCR-Φ4             | M5        | 9  | 20             | 4              | 66666            |
|                    | M6 x 0.75 | 9  | 20             | 4              | 66667            |
|                    | M8 x 1    | 12 | 20             | 5              | 66668            |
|                    | M10 x 1   | 12 | 20             | 7              | 66669            |
| FCR-Φ6             | G1/8"     | 10 | 23             | 8              | 66670            |
|                    | M6 x 0.75 | 12 | 21             | 4              | 66671            |
|                    | M10 x 1   | 12 | 23             | 7              | 66672            |
|                    | G1/8"     | 12 | 23             | 7              | 66673            |
| FCR-Φ8             | G1/4"     | 14 | 25             | 9              | 66674            |
|                    | M10 x 1   | 14 | 27             | 7              | 66675            |
|                    | G1/8"     | 14 | 27             | 8              | 66676            |
|                    | G1/4"     | 14 | 27             | 9              | 66677            |
| FCR-Φ10            | G3/8"     | 17 | 29             | 12             | 66678            |
|                    | G1/8"     | 17 | 30             | 9              | 66679            |
|                    | G1/4"     | 17 | 30             | 9              | 66680            |
|                    | G3/8"     | 17 | 30             | 10             | 66681            |
| FCR-Φ12            | G1/2"     | 22 | 30             | 12             | 66682            |
|                    | G1/4"     | 19 | 30             | 12             | 66683            |
|                    | G3/8"     | 22 | 30             | 12             | 66684            |
| FCR-Φ14            | G1/2"     | 27 | 32             | 14             | 66685            |
|                    | G3/8"     | 22 | 30             | 12             | 66686            |
|                    | G1/2"     | 27 | 32             | 14             | 66687            |

| 型号 d (mm)<br>Model | A         | C  | D  | E   | F   | 订货号<br>Order no. |
|--------------------|-----------|----|----|-----|-----|------------------|
| FCR-AΦ4            | M5        | 15 | 9  | 4   | 2.5 | 66688            |
|                    | M6 x 0.75 | 15 | 9  | 4   | 2.5 | 66689            |
| FCR-AΦ6            | M6 x 0.75 | 17 | 12 | 4   | 2.5 | 66690            |
|                    | M10 x 1   | 17 | 12 | 5   | 3   | 66691            |
| FCR-AΦ8            | G1/8"     | 17 | 12 | 5   | 3   | 66692            |
|                    | M10 x 1   | 16 | 14 | 6   | 5   | 66693            |
| FCR-AΦ10           | G1/4"     | 19 | 14 | 6   | 5   | 66694            |
|                    | G1/4"     | 20 | 16 | 8   | 5   | 66695            |
| FCR-AΦ12           | G3/8"     | 20 | 16 | 8   | 6   | 66696            |
|                    | G1/4"     | 25 | 18 | 8.5 | 8   | 66697            |
|                    | G3/8"     | 25 | 18 | 10  | 8   | 66698            |

| 型号 d (mm)<br>Model | T(牙径)   | S  | L <sub>1</sub> | L <sub>2</sub> | 订货号<br>Order no. |
|--------------------|---------|----|----------------|----------------|------------------|
| FCR-BΦ4            | M6x0.75 | 10 | 28             | 14             | 66699            |
|                    | G1/8"   | 12 | 28             | 14             | 66700            |
| FCR-BΦ6            | M10x1   | 14 | 28             | 14             | 66701            |
|                    | G1/8"   | 14 | 28             | 14             | 66702            |
| FCR-BΦ8            | M14x1.5 | 17 | 33             | 15             | 66703            |
|                    | G1/4"   | 17 | 33             | 15             | 66704            |
| FCR-BΦ10           | M14x1.5 | 17 | 33             | 15             | 66705            |
|                    | G3/8"   | 19 | 33             | 15             | 66706            |
| FCR-BΦ12           | G1/2"   | 27 | 35             | 17             | 66707            |
|                    | M22x1.5 | 27 | 35             | 17             | 66708            |

| 型号 d (mm)<br>Model | T(牙径) | S  | L <sub>1</sub> | K  | 订货号<br>Order no. |
|--------------------|-------|----|----------------|----|------------------|
| FCR-SΦ4            | M10x1 | 12 | 39             | 9  | 66709            |
| FCR-SΦ6            | M14x1 | 14 | 35             | 10 | 66710            |
| FCR-SΦ8            | M16x1 | 19 | 37             | 13 | 66711            |
| FCR-SΦ10           | M18x1 | 22 | 40             | 13 | 66712            |
| FCR-SΦ12           | M20x1 | 27 | 45             | 13 | 66713            |
| FCR-SΦ14           | M22x1 | 27 | 47             | 13 | 66714            |

插入式 FCR 系列气管接头(全铜镀镍)  
FCR Series metal push-in fittings(brass & nickle-plate)

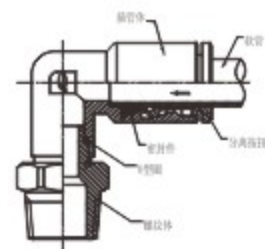

FCR-L 直角螺纹接头(360° 旋转)  
FCR-L Male stud elbow(360° circumrotation)

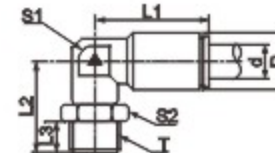

FCR-E 三通中部螺纹接头(360° 旋转)  
FCR-E Stud branch tee(360° circumrotation)

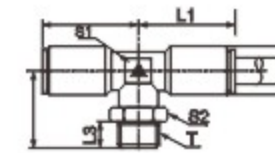

FCR-Y 三通边部螺纹接头(360° 旋转)  
FCR-Y Male stud run tee(360° circumrotation)

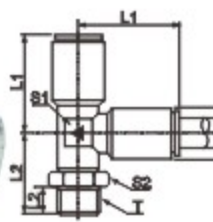

| 型号 d (mm)<br>Model | T(牙径)   | S <sub>1</sub> | S <sub>2</sub> | L <sub>1</sub> | L <sub>2</sub> | L <sub>3</sub> | D  | 订货号<br>Order no. |
|--------------------|---------|----------------|----------------|----------------|----------------|----------------|----|------------------|
| FCR-LΦ4            | M5      | 10             | 10             | 19             | 11             | 4              | 9  | 66715            |
|                    | M6x0.75 | 10             | 10             | 19             | 15             | 4              | 9  | 66716            |
|                    | G1/8"   | 10             | 10             | 19             | 15             | 8              | 9  | 66717            |
| FCR-LΦ6            | G1/4"   | 10             | 14             | 19             | 16             | 9              | 9  | 66718            |
|                    | M6x0.75 | 12             | 12             | 20             | 11             | 4              | 11 | 66719            |
|                    | M10x1   | 12             | 12             | 20             | 15             | 8              | 11 | 66720            |
|                    | G1/8"   | 12             | 10             | 20             | 15             | 8              | 11 | 66721            |
| FCR-LΦ8            | G1/4"   | 12             | 14             | 20             | 16             | 9              | 11 | 66722            |
|                    | M10x1   | 14             | 12             | 25             | 15             | 8              | 13 | 66723            |
|                    | G1/8"   | 14             | 14             | 25             | 15             | 8              | 13 | 66724            |
|                    | G1/4"   | 14             | 14             | 25             | 16             | 9              | 13 | 66725            |
| FCR-LΦ10           | G3/8"   | 14             | 12             | 25             | 17             | 10             | 13 | 66726            |
|                    | G1/8"   | 16             | 14             | 29             | 15             | 8              | 17 | 66727            |
|                    | G1/4"   | 16             | 17             | 29             | 16             | 9              | 17 | 66728            |
| FCR-LΦ12           | G3/8"   | 16             | 19             | 29             | 17             | 10             | 17 | 66729            |
|                    | G1/2"   | 16             | 22             | 29             | 20             | 13             | 17 | 66730            |
|                    | G1/4"   | 18             | 19             | 29             | 22             | 10             | 18 | 66731            |
| FCR-LΦ14           | G3/8"   | 18             | 27             | 29             | 26             | 14             | 18 | 66732            |
|                    | G1/2"   | 18             | 22             | 29             | 24             | 12             | 18 | 66733            |
| FCR-LΦ14           | G3/8"   | 20             | 22             | 29             | 24             | 12             | 20 | 66734            |
|                    | G1/2"   | 20             | 27             | 30             | 24             | 14             | 20 | 66735            |

| 型号 d (mm)<br>Model | T(牙径)   | S <sub>1</sub> | S <sub>2</sub> | L <sub>1</sub> | L <sub>2</sub> | L <sub>3</sub> | 订货号<br>Order no. |
|--------------------|---------|----------------|----------------|----------------|----------------|----------------|------------------|
| FCR-EΦ4            | M5      | 10             | 10             | 19             | 11             | 4              | 66736            |
|                    | M6x0.75 | 10             | 10             | 19             | 15             | 8              | 66737            |
|                    | G1/8"   | 10             | 10             | 19             | 15             | 8              | 66738            |
| FCR-EΦ6            | M10x1   | 12             | 12             | 20             | 16             | 7              | 66739            |
|                    | G1/8"   | 12             | 10             | 20             | 17             | 8              | 66740            |
| FCR-EΦ8            | G1/4"   | 12             | 14             | 20             | 18             | 9              | 66741            |
|                    | G1/8"   | 14             | 14             | 25             | 17             | 8              | 66742            |
|                    | G1/4"   | 14             | 14             | 25             | 20             | 9              | 66743            |
| FCR-EΦ10           | G3/8"   | 14             | 17             | 25             | 21             | 10             | 66744            |
|                    | G1/4"   | 16             | 17             | 29             | 22             | 9              | 66745            |
|                    | G3/8"   | 16             | 19             | 29             | 22             | 9              | 66746            |
| FCR-EΦ12           | G1/2"   | 16             | 19             | 29             | 23             | 10             | 66747            |
|                    | G1/4"   | 18             | 19             | 30             | 30             | 12             | 66748            |
| FCR-EΦ12           | G3/8"   | 18             | 22             | 30             | 30             | 12             | 66749            |
|                    | G1/2"   | 18             | 27             | 30             | 30             | 14             | 66750            |

| 型号 d (mm)<br>Model | T(牙径)   | S <sub>1</sub> | S <sub>2</sub> | L <sub>1</sub> | L <sub>2</sub> | L <sub>3</sub> | 订货号<br>Order no. |
|--------------------|---------|----------------|----------------|----------------|----------------|----------------|------------------|
| FCR-YΦ4            | M5      | 10             | 10             | 19             | 11             | 4              | 66751            |
|                    | M6x0.75 | 10             | 10             | 19             | 15             | 8              | 66752            |
|                    | G1/8"   | 10             | 10             | 19             | 15             | 8              | 66753            |
| FCR-YΦ6            | M10x1   | 12             | 12             | 20             | 15             | 7              | 66754            |
|                    | G1/8"   | 12             | 10             | 20             | 17             | 8              | 66755            |
|                    | G1/4"   | 12             | 14             | 20             | 18             | 9              | 66756            |
| FCR-YΦ8            | G1/8"   | 14             | 14             | 25             | 17             | 8              | 66757            |
|                    | G1/4"   | 14             | 14             | 25             | 20             | 9              | 66758            |
|                    | G3/8"   | 14             | 17             | 25             | 21             | 10             | 66759            |
| FCR-YΦ10           | G1/4"   | 16             | 17             | 29             | 22             | 9              | 66760            |
|                    | G3/8"   | 16             | 19             | 29             | 22             | 9              | 66761            |
|                    | G1/2"   | 16             | 19             | 29             | 23             | 10             | 66762            |
| FCR-YΦ12           | G1/4"   | 18             | 19             | 30             | 30             | 12             | 66763            |
|                    | G3/8"   | 18             | 22             | 30             | 30             | 12             | 66764            |
|                    | G1/2"   | 18             | 27             | 30             | 30             | 14             | 66765            |

插入式 FCR 系列气动管接头(全铜镀镍)  
FCR Series metal push-in fittings(brass & nickle-plate)

FCR-Q 直角铰接式可旋转 (360° 旋转)  
FCR-Q Single banjo(360° circumrotation)

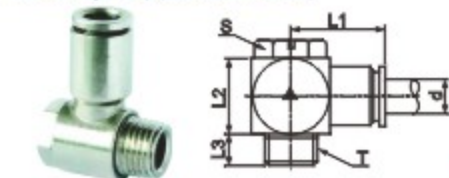

| 型号 d (mm) Model | T(牙径)     | S <sub>1</sub> | L <sub>1</sub> | L <sub>2</sub> | L <sub>3</sub> | 订货号 Order no. |
|-----------------|-----------|----------------|----------------|----------------|----------------|---------------|
| FCR-QΦ4         | M5        | 10             | 19             | 10             | 4              | 66766         |
| FCR-QΦ4         | M6 x 0.75 | 10             | 19             | 10             | 4              | 66767         |
| FCR-QΦ6         | G1/8"     | 12             | 20             | 12             | 8              | 66768         |
| FCR-QΦ6         | M6x 0.75  | 12             | 20             | 12             | 4              | 66769         |
| FCR-QΦ8         | M10x1     | 14             | 25             | 14             | 8              | 66770         |

FCR-I 直通接头 FCR-I Single banjo

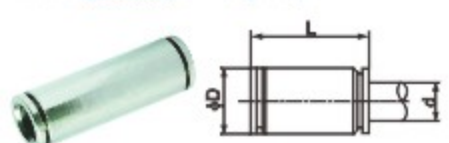

| 型号 d (mm) Model | L  | D  | 订货号 Order no. |
|-----------------|----|----|---------------|
| FCR-IΦ4         | 30 | 10 | 66771         |
| FCR-IΦ6         | 35 | 12 | 66772         |
| FCR-IΦ8         | 37 | 14 | 66773         |
| FCR-IΦ10        | 40 | 16 | 66774         |
| FCR-IΦ12        | 45 | 18 | 66775         |
| FCR-IΦ14        | 50 | 20 | 66776         |

FCR-J 直角接头 FCR-J Union elbow



| 型号 d (mm) Model | S  | L  | 订货号 Order no. |
|-----------------|----|----|---------------|
| FCR-JΦ4         | 10 | 19 | 66777         |
| FCR-JΦ6         | 12 | 20 | 66778         |
| FCR-JΦ8         | 14 | 25 | 66779         |
| FCR-JΦ10        | 16 | 29 | 66780         |
| FCR-JΦ12        | 18 | 34 | 66781         |
| FCR-JΦ14        | 20 | 35 | 66782         |

FCR-T 三通接头 FCR-T Union tee

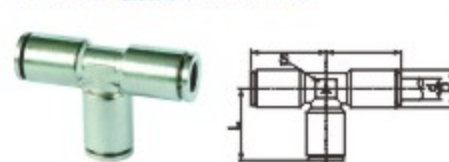

| 型号 d (mm) Model | S  | L  | 订货号 Order no. |
|-----------------|----|----|---------------|
| FCR-TΦ4         | 10 | 19 | 66783         |
| FCR-TΦ6         | 12 | 20 | 66784         |
| FCR-TΦ8         | 14 | 25 | 66785         |
| FCR-TΦ10        | 16 | 29 | 66786         |
| FCR-TΦ12        | 18 | 34 | 66787         |
| FCR-TΦ14        | 20 | 36 | 66788         |

FCR-X 四通接头 FCR-X Union cross



| 型号 d (mm) Model | S  | L  | 订货号 Order no. |
|-----------------|----|----|---------------|
| FCR-XΦ4         | 10 | 19 | 66789         |
| FCR-XΦ6         | 12 | 20 | 66790         |
| FCR-XΦ8         | 14 | 25 | 66791         |
| FCR-XΦ10        | 16 | 29 | 66792         |
| FCR-XΦ12        | 18 | 34 | 66793         |
| FCR-XΦ14        | 20 | 35 | 66794         |

FCR-D 四通螺纹接头(360° 旋转)  
FCR-D Male union cross(360° circumrotation)



| 型号 d (mm) Model | T(牙径)      | S <sub>1</sub> | S <sub>2</sub> | L <sub>1</sub> | L <sub>2</sub> | L <sub>3</sub> | D  | 订货号 Order no. |
|-----------------|------------|----------------|----------------|----------------|----------------|----------------|----|---------------|
| FCR-DΦ4         | M5         | 10             | 10             | 19             | 18             | 4              | 9  | 66795         |
|                 | M10 x 1    | 10             | 12             | 19             | 15             | 8              | 9  | 66796         |
|                 | G1/8"      | 10             | 10             | 19             | 15             | 8              | 9  | 66797         |
| FCR-DΦ6         | M10x 1     | 12             | 12             | 20             | 15             | 8              | 11 | 66798         |
|                 | G1/8"      | 12             | 10             | 20             | 15             | 8              | 11 | 66799         |
|                 | G1/4"      | 12             | 14             | 20             | 16             | 9              | 11 | 66800         |
| FCR-DΦ8         | M12 x 1.25 | 14             | 14             | 25             | 15             | 8              | 13 | 66801         |
|                 | G1/4"      | 14             | 14             | 25             | 16             | 9              | 13 | 66802         |
|                 | G3/8"      | 14             | 17             | 25             | 17             | 10             | 13 | 66803         |
| FCR-DΦ10        | M14 x 1.5  | 16             | 17             | 29             | 16             | 9              | 17 | 66804         |
|                 | G1/4"      | 16             | 14             | 29             | 16             | 9              | 17 | 66805         |
|                 | G3/8"      | 16             | 17             | 29             | 17             | 10             | 17 | 66806         |
| FCR-DΦ12        | M16x 1.5   | 18             | 19             | 30             | 30             | 12             | 18 | 66807         |
|                 | G1/2"      | 18             | 22             | 30             | 30             | 12             | 18 | 66808         |
|                 | M22 x 1.5  | 18             | 27             | 30             | 30             | 14             | 18 | 66809         |

QLAW 系列全黄铜镀镍插入接头式单向节流阀  
QLAW Metal push-in speed controllers

1. 安装螺纹与配套管子外径任意选择, 按需加工
2. 本阀可按要求加工为节流阀。

1. The exterior dia. is available according to demand.
2. The speed controllers can change to their throttle according to demand.

接头式单向节流阀是由单向阀、节流阀及插入式管接头组合而成的流量控制阀。它常控制执行机构两个方向运动的不同速度, 从而达到控制速度目的, 需要快拧式请订货时指明。

Accurate regulation of an optimal air flow rate for precise motion control, the compact design provide the comparable range of speed as the largest standard speed controller do.

QLAW 插入式单向调速阀



| 型号 d (mm) Model | G(牙径)    | H  | L    | J    | 订货号 Order no. |
|-----------------|----------|----|------|------|---------------|
| QLAW-Φ4         | M5       | 25 | 25   | 12   | 66810         |
|                 | M6x 0.75 | 25 | 25   | 12   | 66811         |
| QLAW-Φ6         | G1/8"    | 30 | 32   | 14.5 | 66812         |
|                 | G1/4"    | 30 | 34   | 16.5 | 66813         |
| QLAW-Φ8         | G1/8"    | 30 | 33   | 14.5 | 66814         |
|                 | G1/4"    | 30 | 35   | 16.5 | 66815         |
| QLAW-Φ10        | G1/4"    | 36 | 35.5 | 16.5 | 66816         |
|                 | G3/8"    | 36 | 40   | 20.5 | 66817         |
| QLAW-Φ12        | G3/8"    | 36 | 40   | 20.5 | 66818         |
|                 | G1/2"    | 36 | 45   | 24.5 | 66819         |

QLAWN 快拧式单向调速阀

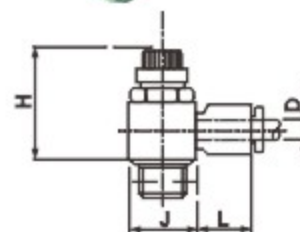

规格表 Specification

|                               |   |      |      |      |      |
|-------------------------------|---|------|------|------|------|
| 管径 ΦSize                      | Φ4, Φ6, Φ8, Φ10, Φ12                    |      |      |      |      |
| 使用流体 Working liquid           | 空气 Air                                  |      |      |      |      |
| 使用压力范围 Working pressure range | 0-9(900)                                |      |      |      |      |
| 保证耐压力 Proof prssure           | 10(1000)                                |      |      |      |      |
| 保证真空压力 Proof vaccum pressure  | -10Kpa ( 10 Torr )                      |      |      |      |      |
| 螺杆回转数 Nut circle              | 10(s)转 Circle                           |      |      |      |      |
| 使用温度范围 Temperature range      | 5-80                                    |      |      |      |      |
| 材料 Material                   | 主体Body 黄铜 ( 镀镍 ) Brass [ nickle-plate ] |      |      |      |      |
| 连接口径 Rc(PT)Connect port       | M5x0.8p                                 | 1/8" | 1/4" | 3/8" | 1/2" |
| 牙部涂胶 Tooth gelatinize         | 耐涂胶印 Offset printing                    |      |      |      |      |

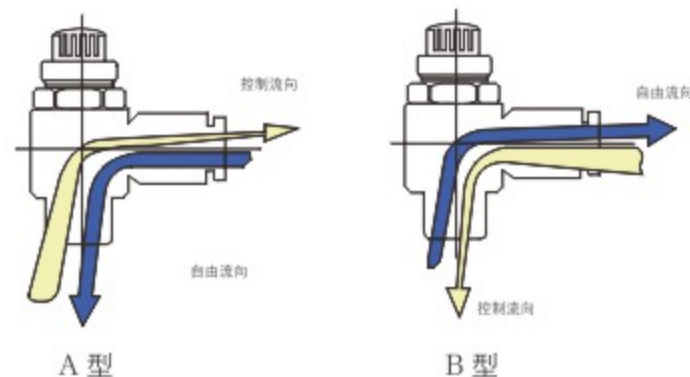

**快拧式 FN 系列气动管接头(全铜镀镍)**  
FN Series metal rapid fittings(brass & nickle-plate)

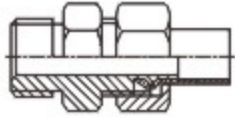

快拧式管接头适用于无腐蚀性气体、液体管路(也适用于真空)。采用PA、PU、PB软管连接(最大接管外径 $\Phi 22\text{mm}$ )具有连接可靠、密封性和反复性好的优点。安装是在固定接头体部分和管子内壁涂上适量润滑油,再锁紧螺母即可。

用户如需其它螺纹规格及其它接管径请订货时标明。

The rapid fittings can be used with rigid nylon tubes(max, exterior dia,  $\Phi 22\text{mm}$ ). A locking nut is provided and can be tightened both manually and with a spanner. The special shape of the guiding cone ensures that the tube can not be accidentally cut.

If user needs other specifications of thread, please state clearly when ordering.

**FN-直通终端管接头 FN-Male stud**

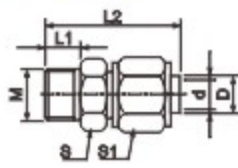

| 型号 d(mm)<br>Model | 接管径D x d<br>pipe dia | 接口螺纹 M<br>Coupling thread |       |           | S  | S <sub>1</sub> | L <sub>1</sub> | L <sub>2</sub> | 订货号 Order no. |
|-------------------|----------------------|---------------------------|-------|-----------|----|----------------|----------------|----------------|---------------|
| FN- $\Phi 4$      | 4x2                  | M6 x 0.75                 | M5    | M6 x 1    | 8  | 8              | 21             | 6              | 66820         |
| FN- $\Phi 6$      | 6x4                  | M10x1                     | G1/8" | M6 x 0.75 | 12 | 10             | 28             | 7              | 66821         |
| FN- $\Phi 8$      | 8x6                  | M10x1                     | G1/8" | G1/4"     | 14 | 13             | 28             | 7              | 66822         |
| FN- $\Phi 10$     | 10x8                 | M12x 1.25                 | G1/4" | G3/8"     | 17 | 15             | 30             | 8              | 66823         |
| FN- $\Phi 12$     | 12x10                | M16x1.5                   | G3/8" | G1/2"     | 22 | 18             | 33             | 10             | 66824         |
| FN- $\Phi 14$     | 14x12                | M18x1.5                   | G3/4" | G1/2"     | 27 | 21             | 39             | 12             | 66825         |

**FN-B 直角终端内螺接头 FN-Female stud**

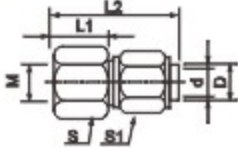

| 型号 d(mm)<br>Model | 接管径D x d<br>pipe dia | 接口螺纹 M<br>Coupling thread |       |           | S  | S <sub>1</sub> | L <sub>1</sub> | L <sub>2</sub> | 订货号 Order no. |
|-------------------|----------------------|---------------------------|-------|-----------|----|----------------|----------------|----------------|---------------|
| FN-B $\Phi 4$     | 4x2                  | M6 x 0.75                 | M5    | M6 x 1    | 8  | 8              | 8              | 19             | 66826         |
| FN-B $\Phi 6$     | 6x4                  | M10x1                     | G1/8" | M6 x 0.75 | 12 | 10             | 10             | 21             | 66827         |
| FN-B $\Phi 8$     | 8x6                  | M10x1                     | G1/8" | G1/4"     | 17 | 13             | 13             | 25             | 66828         |
| FN-B $\Phi 10$    | 10x8                 | M12x 1.25                 | G1/4" | G3/8"     | 19 | 15             | 14.5           | 28.5           | 66829         |
| FN-B $\Phi 12$    | 12x10                | M16x1.5                   | G3/8" | G1/2"     | 24 | 18             | 15             | 31             | 66830         |
| FN-B $\Phi 14$    | 14x12                | M18x1.5                   | G3/4" | G1/2"     | 27 | 21             | 16             | 34             | 66831         |

**FN-L 直通终端管接头 360° 旋转**

FN-L Male stud elbow(360° circumrotation)

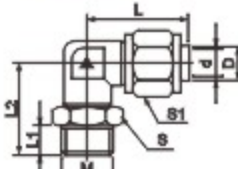

| 型号 d(mm)<br>Model | 接管径D x d<br>pipe dia | 接口螺纹 M<br>Coupling thread |       |           | S  | S <sub>1</sub> | L <sub>1</sub> | L <sub>2</sub> | L <sub>3</sub> | 订货号 Order no. |
|-------------------|----------------------|---------------------------|-------|-----------|----|----------------|----------------|----------------|----------------|---------------|
| FN-L $\Phi 4$     | 4x2                  | M6 x 0.75                 | M5    | M6 x 1    | 8  | 8              | 21             | 6              | 20             | 66832         |
| FN-L $\Phi 6$     | 6x4                  | M10x1                     | G1/8" | M6 x 0.75 | 12 | 10             | 23             | 7              | 22             | 66833         |
| FN-L $\Phi 8$     | 8x6                  | M10x1                     | G1/8" | G1/4"     | 14 | 13             | 24             | 7              | 23             | 66834         |
| FN-L $\Phi 10$    | 10x8                 | M12x 1.25                 | G1/4" | G3/8"     | 17 | 15             | 28             | 9              | 26             | 66835         |
| FN-L $\Phi 12$    | 12x10                | M16x1.5                   | G3/8" | G1/2"     | 22 | 18             | 33             | 10             | 30             | 66836         |
| FN-L $\Phi 14$    | 14x12                | M18x1.5                   | G3/4" | G1/2"     | 27 | 21             | 35             | 12             | 32             | 66837         |

**FN-E 三通中部终端管接头 360° 旋转**

FN-E Male stud branch tee(360° circumrotation)

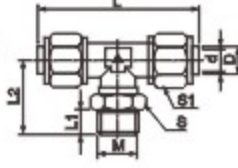

| 型号 d(mm)<br>Model | 接管径D x d<br>pipe dia | 接口螺纹 M<br>Coupling thread |       |           | S  | S <sub>1</sub> | L <sub>1</sub> | L <sub>2</sub> | L <sub>3</sub> | 订货号 Order no. |
|-------------------|----------------------|---------------------------|-------|-----------|----|----------------|----------------|----------------|----------------|---------------|
| FN-E $\Phi 4$     | 4x2                  | M6 x 0.75                 | M5    | M6 x 1    | 8  | 8              | 42             | 6              | 20             | 66838         |
| FN-E $\Phi 6$     | 6x4                  | M10x1                     | G1/8" | M6 x 0.75 | 12 | 10             | 46             | 7              | 22             | 66839         |
| FN-E $\Phi 8$     | 8x6                  | M10x1                     | G1/8" | G1/4"     | 14 | 12             | 48             | 7              | 23             | 66840         |
| FN-E $\Phi 10$    | 10x8                 | M12x 1.25                 | G1/4" | G3/8"     | 17 | 14             | 56             | 9              | 26             | 66841         |
| FN-E $\Phi 12$    | 12x10                | M16x1.5                   | G3/8" | G1/2"     | 22 | 17             | 66             | 10             | 30             | 66842         |
| FN-E $\Phi 14$    | 14x12                | M18x1.5                   | G3/4" | G1/2"     | 27 | 19             | 70             | 12             | 32             | 66843         |

**FN-Y 三通边部终端管接头 360° 旋转**

FN-Y Male stude run tee(360° circumrotation)

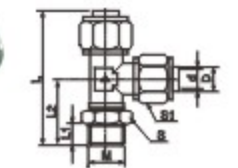

| 型号 d(mm)<br>Model | 接管径D x d<br>pipe dia | 接口螺纹 M<br>Coupling thread |       |           | S  | S <sub>1</sub> | L <sub>1</sub> | L <sub>2</sub> | L <sub>3</sub> | 订货号 Order no. |
|-------------------|----------------------|---------------------------|-------|-----------|----|----------------|----------------|----------------|----------------|---------------|
| FN-Y $\Phi 4$     | 4x2                  | M6 x 0.75                 | M5    | M6 x 1    | 8  | 8              | 42             | 6              | 20             | 66844         |
| FN-Y $\Phi 6$     | 6x4                  | M10x1                     | G1/8" | M6 x 0.75 | 12 | 10             | 46             | 7              | 22             | 66845         |
| FN-Y $\Phi 8$     | 8x6                  | M10x1                     | G1/8" | G1/4"     | 14 | 13             | 48             | 7              | 23             | 66846         |
| FN-Y $\Phi 10$    | 10x8                 | M12x 1.25                 | G1/4" | G3/8"     | 17 | 15             | 56             | 9              | 26             | 66847         |
| FN-Y $\Phi 12$    | 12x10                | M16x1.5                   | G3/8" | G1/2"     | 22 | 18             | 66             | 10             | 30             | 66848         |
| FN-Y $\Phi 14$    | 14x12                | M18x1.5                   | G3/4" | G1/2"     | 27 | 21             | 70             | 12             | 32             | 66849         |

**快拧式 FN 系列气动管接头(全铜镀镍)**  
FN Series metal rapid fittings(brass & nickle-plate)

**FN-I 直通管接头 FN-I Male stud run tee**

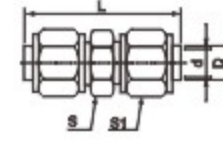

| 型号 d(mm)<br>Model | 接管径D x d<br>pipe dia | S  | S <sub>1</sub> | L  | 订货号 Order no. |
|-------------------|----------------------|----|----------------|----|---------------|
| FN-I $\Phi 4$     | 4x2.5                | 8  | 8              | 30 | 66850         |
| FN-I $\Phi 6$     | 6x4                  | 10 | 10             | 32 | 66851         |
| FN-I $\Phi 8$     | 8x6                  | 12 | 13             | 35 | 66852         |
| FN-I $\Phi 10$    | 10x8                 | 14 | 15             | 39 | 66853         |
| FN-I $\Phi 12$    | 12x10                | 17 | 18             | 45 | 66854         |
| FN-I $\Phi 14$    | 14x12                | 19 | 21             | 50 | 66855         |

**FN-S 直通穿板接头 FN-S Bulkhead union**

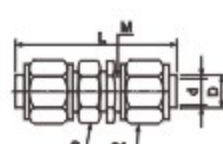

| 型号 d(mm)<br>Model | 接管径D x d<br>pipe dia | S  | S <sub>1</sub> | L  | M  | 订货号 Order no. |
|-------------------|----------------------|----|----------------|----|----|---------------|
| FN-S $\Phi 4$     | 4x2.5                | 8  | 8              | 29 | 6  | 66856         |
| FN-S $\Phi 6$     | 6x4                  | 10 | 10             | 33 | 8  | 66857         |
| FN-S $\Phi 8$     | 8x6                  | 12 | 13             | 35 | 11 | 66858         |
| FN-S $\Phi 10$    | 10x8                 | 15 | 15             | 39 | 13 | 66859         |
| FN-S $\Phi 12$    | 12x10                | 19 | 18             | 43 | 16 | 66860         |
| FN-S $\Phi 14$    | 14x12                | 21 | 21             | 48 | 18 | 66861         |

**FN-J 直角管接头 FN-J Union elbow**

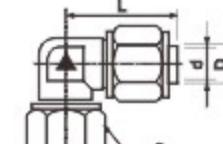

| 型号 d(mm)<br>Model | 接管径D x d<br>pipe dia | S  | L  | 订货号 Order no. |
|-------------------|----------------------|----|----|---------------|
| FN-J $\Phi 4$     | 4x2.5                | 8  | 20 | 66862         |
| FN-J $\Phi 6$     | 6x4                  | 10 | 22 | 66863         |
| FN-J $\Phi 8$     | 8x6                  | 13 | 23 | 66864         |
| FN-J $\Phi 10$    | 10x8                 | 15 | 26 | 66865         |
| FN-J $\Phi 12$    | 12x10                | 18 | 30 | 66866         |
| FN-J $\Phi 14$    | 14x12                | 21 | 35 | 66867         |

**FN-T 三通管接头 FN-T Union tee**

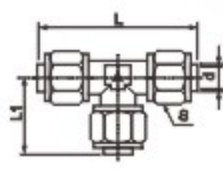

| 型号 d(mm)<br>Model | 接管径D x d<br>pipe dia | S  | L  | L <sub>1</sub> | 订货号 Order no. |
|-------------------|----------------------|----|----|----------------|---------------|
| FN-T $\Phi 4$     | 4x2.5                | 8  | 42 | 23             | 66868         |
| FN-T $\Phi 6$     | 6x4                  | 10 | 46 | 23             | 66869         |
| FN-T $\Phi 8$     | 8x6                  | 13 | 48 | 24             | 66870         |
| FN-T $\Phi 10$    | 10x8                 | 15 | 56 | 28             | 66871         |
| FN-T $\Phi 12$    | 12x10                | 18 | 66 | 33             | 66872         |
| FN-T $\Phi 14$    | 14x12                | 21 | 70 | 35             | 66873         |

**FN-X 四通管接头 FN-X Union cross**

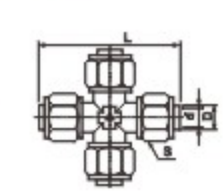

| 型号 d(mm)<br>Model | 接管径D x d<br>pipe dia | S  | L  | 订货号 Order no. |
|-------------------|----------------------|----|----|---------------|
| FN-X $\Phi 4$     | 4x2.5                | 8  | 42 | 66874         |
| FN-X $\Phi 6$     | 6x4                  | 10 | 46 | 66875         |
| FN-X $\Phi 8$     | 8x6                  | 13 | 48 | 66876         |
| FN-X $\Phi 10$    | 10x8                 | 15 | 56 | 66877         |
| FN-X $\Phi 12$    | 12x10                | 18 | 66 | 66878         |
| FN-X $\Phi 14$    | 14x12                | 21 | 70 | 66879         |

**FN-D 四通终端管接头 360° 旋转**

FN-D Male union cross(360° circumrotation)

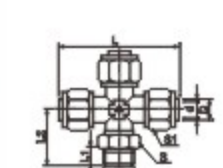

| 型号 d(mm)<br>Model | 接管径D x d<br>pipe dia | 接口螺纹 M<br>Coupling thread |       |           | S  | S <sub>1</sub> | L <sub>1</sub> | L <sub>2</sub> | L <sub>3</sub> | 订货号 Order no. |
|-------------------|----------------------|---------------------------|-------|-----------|----|----------------|----------------|----------------|----------------|---------------|
| FN-D $\Phi 4$     | 4x2.5                | M6 x 0.75                 | M5    | M6 x 1    | 8  | 8              | 42             | 6              | 20             | 66880         |
| FN-D $\Phi 6$     | 6x4                  | M10x1                     | G1/8" | M6 x 0.75 | 12 | 10             | 46             | 7              | 22             | 66881         |
| FN-D $\Phi 8$     | 8x6                  | M10x1                     | G1/8" | G1/4"     | 14 | 13             | 48             | 7              | 23             | 66882         |
| FN-D $\Phi 10$    | 10x8                 | M12x 1.25                 | G1/4" | G3/8"     | 17 | 15             | 56             | 9              | 26             | 66883         |
| FN-D $\Phi 12$    | 12x10                | M16x1.5                   | G3/8" | G1/2"     | 22 | 18             | 66             | 10             | 30             | 66884         |
| FN-D $\Phi 14$    | 14x12                | M18x1.5                   | G3/4" | G1/2"     | 27 | 21             | 70             | 12             | 32             | 66885         |

**卡套式 FK 系列气动管接头(全铜镀镍)**  
FK Series metal pipe joint fittings(brass & nickle-plate)

FK-卡套式管接头配管为紫铜管、硬尼龙管, 工作压力达1.6MPa, Working pressure can reach to 1.6MPa.  
用户如需其它螺纹规格的请订货时指明, If user needs other specifications of thread, please state clearly when ordering.

**FK-直通终端管接头 FK-Male stud**

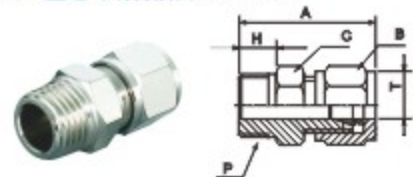

| 型号 T [mm]<br>Model | P(牙径) | A  | B  | C  | M  | 订货号 Order no. |
|--------------------|-------|----|----|----|----|---------------|
| FK-4               | G1/8" | 24 | 10 | 10 | 5  | 66886         |
| FK-6               | G1/8" | 25 | 12 | 12 | 6  | 66887         |
| FK-8               | G1/4" | 30 | 14 | 14 | 7  | 66888         |
| FK-10              | G3/8" | 33 | 17 | 17 | 9  | 66889         |
| FK-12              | G1/2" | 38 | 19 | 22 | 12 | 66900         |
| FK-14              | G3/4" | 45 | 22 | 29 | 14 | 66901         |

**FK-L 直角终端管接头 FK-L Male stud elbow**



| 型号 T [mm]<br>Model | P(牙径) | A  | B  | C  | M  | 订货号 Order no. |
|--------------------|-------|----|----|----|----|---------------|
| FK-LΦ4             | G1/8" | 19 | 10 | 10 | 16 | 66902         |
| FK-LΦ6             | G1/8" | 20 | 12 | 12 | 20 | 66903         |
| FK-LΦ8             | G1/4" | 22 | 14 | 14 | 28 | 66904         |
| FK-LΦ10            | G3/8" | 25 | 17 | 17 | 26 | 66905         |
| FK-LΦ12            | G1/2" | 28 | 19 | 22 | 30 | 66906         |
| FK-LΦ14            | G3/4" | 30 | 22 | 29 | 40 | 66907         |

**FK-Y 三通边部终端管接头  
FK-Y Male stud run tee**



| 型号 T [mm]<br>Model | P(牙径) | A  | B  | C  | M  | 订货号 Order no. |
|--------------------|-------|----|----|----|----|---------------|
| FK-YΦ4             | G1/8" | 35 | 10 | 16 | 19 | 66908         |
| FK-YΦ6             | G1/8" | 4  | 12 | 20 | 20 | 66909         |
| FK-YΦ8             | G1/4" | 44 | 14 | 23 | 22 | 66910         |
| FK-YΦ10            | G3/8" | 50 | 17 | 26 | 25 | 66911         |
| FK-YΦ12            | G1/2" | 56 | 19 | 30 | 28 | 66912         |
| FK-YΦ14            | G3/4" | 60 | 22 | 40 | 30 | 66913         |

**FK-I 直通管接头 FK-I Union straight**



| 型号 T [mm]<br>Model | A  | B  | C  | 订货号 Order no. |
|--------------------|----|----|----|---------------|
| FK-IΦ4             | 30 | 10 | 10 | 66914         |
| FK-IΦ6             | 34 | 12 | 12 | 66915         |
| FK-IΦ8             | 37 | 14 | 14 | 66916         |
| FK-IΦ10            | 40 | 17 | 17 | 66917         |
| FK-IΦ12            | 46 | 19 | 19 | 66918         |
| FK-IΦ14            | 50 | 22 | 22 | 66919         |

**FK-T 三通管接头 FK-T Union tee**



| 型号 T [mm]<br>Model | A  | B  | M  | 订货号 Order no. |
|--------------------|----|----|----|---------------|
| FK-TΦ4             | 35 | 10 | 19 | 66920         |
| FK-TΦ6             | 40 | 12 | 20 | 66922         |
| FK-TΦ8             | 44 | 14 | 22 | 66923         |
| FK-TΦ10            | 50 | 17 | 25 | 66924         |
| FK-TΦ12            | 56 | 19 | 28 | 66925         |
| FK-TΦ14            | 60 | 22 | 30 | 66926         |

**FK-E 三通中部螺纹接头 FK Male union tee**



| 型号 T [mm]<br>Model | A  | B1 | B2   | M  | 订货号 Order no. |
|--------------------|----|----|------|----|---------------|
| FK-EΦ4             | 35 | 10 | 1/8" | 19 | 66927         |
| FK-EΦ6             | 40 | 12 | 1/8" | 20 | 66928         |
| FK-EΦ8             | 44 | 14 | 1/4" | 22 | 66929         |
| FK-EΦ10            | 50 | 17 | 3/8" | 25 | 66930         |
| FK-EΦ12            | 56 | 19 | 1/2" | 28 | 66931         |
| FK-EΦ14            | 60 | 22 | 1/2" | 30 | 66932         |

**FK-S 直通穿板 FK-S Bulkhead union**



| 型号 T [mm]<br>Model | A  | B(牙径) | C  | 订货号 Order no. |
|--------------------|----|-------|----|---------------|
| FK-SΦ4             | 38 | 10    | 10 | 66933         |
| FK-SΦ6             | 42 | 12    | 12 | 66934         |
| FK-SΦ8             | 45 | 14    | 14 | 66935         |
| FK-SΦ10            | 48 | 17    | 17 | 66936         |
| FK-SΦ12            | 54 | 19    | 19 | 66937         |
| FK-SΦ14            | 58 | 22    | 22 | 66938         |

**活络式 FW 系列管接头(全铜镀镍)**  
FW Series metal plug-in fittings(brass & nickle-plate)

(一) (FW)-系列活络式管接头, 适用于连接软质尼龙管, 塑料管及胶管, 最大工作压力为1.0MPa该系列接头具有结构简单使用方便, 安装牢固等优点。  
(二) 将卡箍先套在气管上, 在外插头终端外表涂适量润滑油, 再插入气管, 锁紧卡箍。  
用户如需其它螺纹规格的请订货时指明。

(1) YPW-series adjustable pipe coupling, is applicable for connecting the soft nylon pipe, plastic pipe and rubber tube. Its max working pressure is 1.0MPa. It has manyadvanta  
gesuch as simple structure, convenience in use, firm installation and so on.  
(2) Put the clip on the gas pipe, coat the proper lubricating oil on the surface of external plug terminal, then insert the gas pipe and fasten the clip. If user needs otherspecificatio  
ns of thread, please state clearly when ordering.

**FW 直通终端管接头 FW Male plug-in stud**

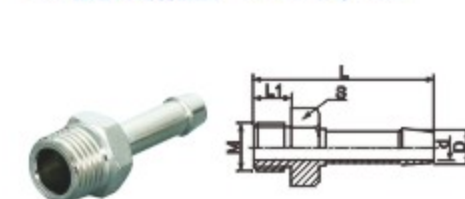

| 型号<br>Model | 公称直径<br>Nominal dia | 接管径 D<br>pipe inner dia | 接口螺纹 M<br>Coupling thread |           |         | S  | L  | L1 | 订货号 Order no. |
|-------------|---------------------|-------------------------|---------------------------|-----------|---------|----|----|----|---------------|
| FW-2.5      | Φ2.5                | 3                       | M5                        | -         | -       | 8  | 30 | 6  | 66936         |
| FW-3        | Φ3                  | 4                       | M5x1                      | M6 x 0.75 | M8 x 1  | 10 | 30 | 6  | 66940         |
| FW-4        | Φ4                  | 5                       | M8x1                      | M10x1     | M1/8"   | 12 | 34 | 7  | 66941         |
| FW-5        | Φ6                  | 6                       | M10x1                     | G1/8"     | G1/4"   | 14 | 37 | 7  | 66942         |
| FW-8        | Φ8                  | 8                       | M12x1.25                  | G1/4"     | G3/8"   | 17 | 43 | 9  | 66943         |
| FW-10       | Φ10                 | 10                      | M16x1.5                   | G3/8"     | G1/2"   | 19 | 49 | 10 | 66944         |
| FW-15       | Φ15                 | 15                      | M20x1.5                   | G1/2"     | G3/4"   | 24 | 55 | 11 | 66945         |
| FW-20       | Φ20                 | 20                      | M27x2                     | G3/4"     | G1      | 30 | 63 | 13 | 66946         |
| FW-25       | Φ25                 | 25                      | M33x2                     | G1        | G1 1/2" | 36 | 70 | 15 | 66947         |

**FW-K 直通终端活节管接头  
FW-K Male plug-in stud with activity**



| 型号<br>Model | 公称直径<br>Nominal dia | 接管径 D<br>pipe inner dia | 接口螺纹 M<br>Coupling thread |           |         | S  | S1 | L  | L1 | 订货号 Order no. |
|-------------|---------------------|-------------------------|---------------------------|-----------|---------|----|----|----|----|---------------|
| FW-K2.5     | Φ2.5                | 3                       | M5                        | -         | -       | 8  | 8  | 30 | 6  | 66948         |
| FW-K3       | Φ3                  | 4                       | M5x1                      | M6 x 0.75 | M8 x 1  | 10 | 10 | 30 | 6  | 66949         |
| FW-K4       | Φ4                  | 5                       | M8x1                      | M10x1     | M1/8"   | 12 | 12 | 34 | 7  | 66950         |
| FW-K5       | Φ6                  | 6                       | M10x1                     | G1/8"     | G1/4"   | 14 | 14 | 37 | 7  | 66951         |
| FW-K8       | Φ8                  | 8                       | M12x1.25                  | G1/4"     | G3/8"   | 17 | 17 | 43 | 9  | 66952         |
| FW-K10      | Φ10                 | 10                      | M16x1.5                   | G3/8"     | G1/2"   | 19 | 22 | 49 | 10 | 66953         |
| FW-K15      | Φ15                 | 15                      | M20x1.5                   | G1/2"     | G3/4"   | 24 | 27 | 55 | 11 | 66954         |
| FW-K20      | Φ20                 | 20                      | M27x2                     | G3/4"     | G1      | 30 | 36 | 63 | 13 | 66955         |
| FW-K25      | Φ25                 | 25                      | M33x2                     | G1"       | G1 1/2" | 36 | 41 | 70 | 15 | 66956         |

**FW-I 直通活节管接头  
FW-I Plug in uAnion straight with activity**



| 型号<br>Model | 公称直径<br>Nominal dia | 接管径 D<br>pipe inner dia | S  | S1 | L   | 订货号 Order no. |
|-------------|---------------------|-------------------------|----|----|-----|---------------|
| FW-I3       | Φ3                  | 4                       | 10 | 10 | 70  | 66957         |
| FW-I4       | Φ4                  | 5                       | 12 | 12 | 72  | 66958         |
| FW-I5       | Φ6                  | 6                       | 14 | 14 | 79  | 66959         |
| FW-I8       | Φ8                  | 8                       | 17 | 17 | 94  | 66960         |
| FW-I10      | Φ10                 | 10                      | 19 | 22 | 105 | 66961         |
| FW-I15      | Φ15                 | 15                      | 24 | 27 | 115 | 66962         |
| FW-I20      | Φ20                 | 20                      | 30 | 36 | 130 | 66963         |
| FW-I25      | Φ25                 | 25                      | 36 | 41 | 148 | 66964         |

**FW-L 直角终端活节管接头 360° 旋转  
FW-L Male plug-in elbow with activity  
(360° circumrotation)**

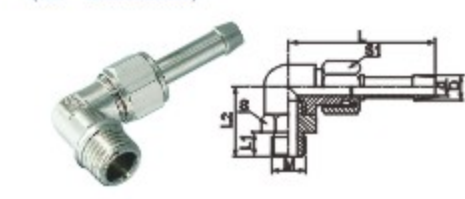

| 型号<br>Model | 公称直径<br>Nominal dia | 接管径 D<br>pipe inner dia | 接口螺纹 M<br>Coupling thread |           |       | S  | S1 | L  | L1 | 订货号 Order no. |       |
|-------------|---------------------|-------------------------|---------------------------|-----------|-------|----|----|----|----|---------------|-------|
| FW-L2.5     | Φ2.5                | 3                       | M5                        | -         | -     | 8  | 8  | 43 | 6  | 23            | 66965 |
| FW-L3       | Φ3                  | 4                       | M6x1                      | M6 x 0.75 | M8x1  | 10 | 10 | 42 | 6  | 23            | 66966 |
| FW-L4       | Φ4                  | 5                       | M8x1                      | M10x1     | G1/8" | 12 | 12 | 45 | 7  | 25            | 66967 |
| FW-L6       | Φ6                  | 6                       | M10x1                     | G1/8"     | G1/4" | 14 | 14 | 50 | 7  | 28            | 66968 |
| FW-L8       | Φ8                  | 8                       | M12x1.25                  | G1/4"     | G3/8" | 17 | 17 | 53 | 9  | 30            | 66969 |
| FW-L10      | Φ10                 | 10                      | M16x1.5                   | G3/8"     | G1/2" | 19 | 22 | 62 | 10 | 34            | 66970 |
| FW-L15      | Φ15                 | 15                      | M20x1.5                   | G1/2"     | G3/4" | 24 | 27 | 70 | 11 | 36            | 66971 |
| FW-L25      | Φ25                 | 25                      | M27x2                     | G3/4"     | G1"   | 30 | 36 | 92 | 13 | 40            | 66972 |

**宝塔式 FB 系列管接头(全铜镀镍)**  
FB Series metal stand pipe fittings(brass & nickle-plate)

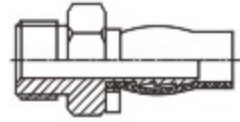

(一) FB-系列宝塔式接头, 适用于连接软质尼龙管, 塑料管及胶管。  
(二) 将卡箍先套在气管上, 在外宝塔头端外涂适量润滑油, 再插入气管, 锁紧卡箍。  
用户如需其它螺纹规格的请订货时指明。  
(1) YPB-series tower coupling, is suitable for connecting the soft nylon pipe, plastic pipe and rubber tube.  
(2) Put the clip on the gas pipe, coat the proper lubricating oil on the surface of external tower end, then insert the gas pipe and fasten the clip.  
If user needs other specifications of thread, please state clearly when ordering.

**FB-直通终端管接头**  
FB-Male plug-in barb stud

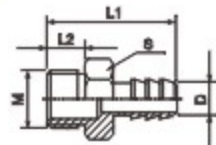

**FB-B 直通终端内螺纹管接头**  
FB-B Female plug-in barb stud

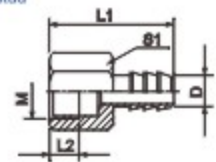

**FB-L 直角终端管接头 360° 旋转**  
FB-L Male plug-in barb stud elbow(360° circumrotation)

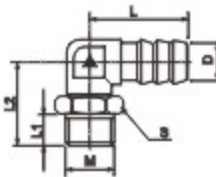

**FB-E 三通终端管接头 360° 旋转**  
FB-E Male plug-in bar stud branch tee (360° circumrotation)

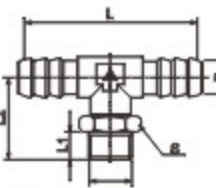

**FB-T 三通接头**  
FB-T Plug-in barb union tee

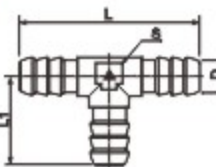

| 型号 Model | 公称内径 D Nominal inne dia | 接口螺纹 M Coupling thread | S     | L  | L <sub>1</sub> | L <sub>2</sub> | 订货号 Order no. |       |
|----------|-------------------------|------------------------|-------|----|----------------|----------------|---------------|-------|
| FB-3     | Φ2.5                    | M6x1                   | M5    | 10 | 10             | 17             | 6             | 66973 |
| FB-4     | Φ4                      | M10x1                  | G1/8" | 12 | 14             | 19             | 7             | 66974 |
| FB-6     | Φ6                      | M10x1                  | G1/8" | 14 | 14             | 20             | 7             | 66975 |
| FB-8     | Φ8                      | M12x1.25               | G1/4" | 17 | 17             | 25             | 9             | 66976 |
| FB-10    | Φ10                     | M16x1.5                | G3/8" | 19 | 19             | 27             | 10            | 66977 |
| FB-14    | Φ14                     | M20x1.5                | G1/2" | 24 | 27             | 30             | 11            | 66978 |
| FB-20    | Φ20                     | M27x2                  | G3/4" | 27 | 32             | 34             | 13            | 66979 |
| FB-25    | Φ25                     | M33x2                  | G1"   | 30 | 42             | 40             | 15            | 66980 |

| 型号 Model | 公称内径 D Nominal inne dia | 接口螺纹 M Coupling thread | S     | L       | L <sub>1</sub> | L <sub>2</sub> | 订货号 Order no. |    |       |
|----------|-------------------------|------------------------|-------|---------|----------------|----------------|---------------|----|-------|
| FB-L3    | Φ2.5                    | M6x1                   | M5    | M6x0.75 | 8              | 21             | 6             | 20 | 66981 |
| FB-L4    | Φ4                      | M8x1                   | M10x1 | G1/8"   | 12             | 23             | 7             | 22 | 66982 |
| FB-L6    | Φ6                      | M10x1                  | G1/8" | G1/4"   | 14             | 24             | 7             | 23 | 66983 |
| FB-L8    | Φ8                      | M12x1.25               | G1/4" | G3/8"   | 17             | 28             | 9             | 26 | 66984 |
| FB-L10   | Φ10                     | M16x1.5                | G3/8" | G1/2"   | 22             | 33             | 10            | 30 | 66985 |
| FB-L14   | Φ14                     | M18x1.5                | G3/8" | G1/2"   | 22             | 35             | 12            | 33 | 66986 |
| FB-L20   | Φ20                     | M22x1.5                | M27x2 | G3/4"   | 27             | 42             | 14            | 38 | 66987 |

| 型号 Model | 公称内径 D Nominal inne dia | 接口螺纹 M Coupling thread | S     | L       | L <sub>1</sub> | L <sub>2</sub> | 订货号 Order no. |    |       |
|----------|-------------------------|------------------------|-------|---------|----------------|----------------|---------------|----|-------|
| FB-E3    | Φ2.5                    | M6x1                   | M5    | M6x0.75 | 8              | 42             | 6             | 20 | 66988 |
| FB-E4    | Φ4                      | M8x1                   | M10x1 | G1/8"   | 12             | 46             | 7             | 22 | 66989 |
| FB-E6    | Φ6                      | M10x1                  | G1/8" | G1/4"   | 14             | 48             | 7             | 23 | 66990 |
| FB-E8    | Φ8                      | M12x1.25               | G1/4" | G3/8"   | 17             | 56             | 9             | 26 | 66991 |
| FB-E10   | Φ10                     | M16x1.5                | G3/8" | G1/2"   | 22             | 66             | 10            | 30 | 66992 |

| 型号 Model | 公称内径 D Nominal inne dia | S  | L  | 订货号 Order no. |       |
|----------|-------------------------|----|----|---------------|-------|
| FB-T3    | Φ2.5                    | 4  | 42 | 21            | 66993 |
| FB-T4    | Φ4                      | 6  | 46 | 23            | 66994 |
| FB-T6    | Φ6                      | 8  | 48 | 24            | 66995 |
| FB-T8    | Φ8                      | 10 | 56 | 28            | 66996 |
| FB-T10   | Φ10                     | 12 | 66 | 33            | 66997 |
| FB-T12   | Φ12                     | 14 | 68 | 38            | 66998 |
| FB-T14   | Φ14                     | 16 | 76 | 45            | 66999 |

**内外螺纹接头系列**  
Female and male thread connector series

**FZH 螺三通外部螺纹**  
FZH Male stud run tee

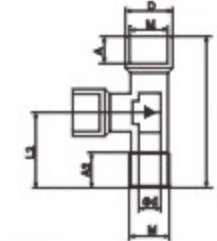

| 型号 d(mm) Model | 公称通径 Φd Pipe dia | 接口螺纹 M Coupling thread | L <sub>1</sub> | L <sub>2</sub> | A <sub>1</sub> | A <sub>2</sub> | D  | 订货号 Order no. |
|----------------|------------------|------------------------|----------------|----------------|----------------|----------------|----|---------------|
| FZH-4          | 4                | M8x1                   | 37             | 18.5           | 7              | 6              | 12 | 67000         |
| FZH-6          | 6                | M10x1                  | 39             | 19.5           | 8              | 9              | 12 | 67001         |
| FZH-8          | 8                | M12x1.25               | 47             | 23.5           | 11             | 11             | 17 | 67002         |
| FZH-10         | 10               | M16x1.5                | 52             | 26             | 12             | 13             | 20 | 67003         |
| FZH-15         | 15               | M20x1.5                | 59             | 28             | 12             | 15             | 24 | 67004         |

**FTH 正三通内螺纹**  
FTH Union tee

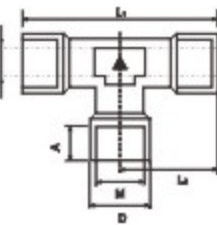

| 型号 d(mm) Model | 公称通径 Φd Pipe dia | 接口螺纹 M Coupling thread | L <sub>1</sub> | L <sub>2</sub> | A  | D  | 订货号 Order no. |
|----------------|------------------|------------------------|----------------|----------------|----|----|---------------|
| FTH-4          | 4                | M8x1                   | 37             | 18.5           | 7  | 12 | 67005         |
| FTH-6          | 6                | M10x1                  | 39             | 19.5           | 8  | 12 | 67006         |
| FTH-8          | 8                | M12x1.25               | 47             | 23.5           | 11 | 17 | 67007         |
| FTH-10         | 10               | M16x1.5                | 52             | 26             | 12 | 20 | 67008         |
| FTH-15         | 15               | M20x1.5                | 59             | 28             | 12 | 24 | 67009         |

**FDH 内螺三通中部外螺纹**  
FDH Male stud run tee

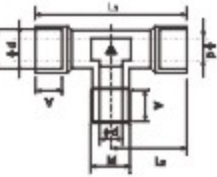

| 型号 d(mm) Model | 公称通径 Φd Pipe dia | 接口螺纹 M Coupling thread | L <sub>1</sub> | L <sub>2</sub> | A  | A <sub>2</sub> | D  | 订货号 Order no. |
|----------------|------------------|------------------------|----------------|----------------|----|----------------|----|---------------|
| FDH-4          | 4                | M8x1                   | 37             | 18.5           | 7  | 6              | 12 | 67010         |
| FDH-6          | 6                | M10x1                  | 39             | 19.5           | 8  | 9              | 12 | 67011         |
| FDH-8          | 8                | M12x1.25               | 47             | 23.5           | 11 | 11             | 17 | 67012         |
| FDH-10         | 10               | M16x1.5                | 52             | 26             | 12 | 13             | 20 | 67013         |
| FDH-15         | 15               | M20x1.5                | 59             | 28             | 12 | 15             | 24 | 67014         |

**FJH 直角内螺纹**  
FJH Stud elbow

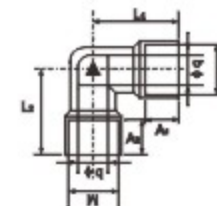

| 型号 d(mm) Model | 公称通径 Φd Pipe dia | 接口螺纹 M Coupling thread | L <sub>1</sub> | L <sub>2</sub> | A  | A <sub>2</sub> | D  | 订货号 Order no. |
|----------------|------------------|------------------------|----------------|----------------|----|----------------|----|---------------|
| FJH-4          | 4                | M8x1                   | 37             | 18.5           | 7  | 6              | 12 | 67015         |
| FJH-6          | 6                | M10x1                  | 39             | 19.5           | 8  | 9              | 12 | 67016         |
| FJH-8          | 8                | M12x1.25               | 47             | 23.5           | 11 | 11             | 17 | 67017         |
| FJH-10         | 10               | M16x1.5                | 52             | 26             | 12 | 13             | 20 | 67018         |
| FJH-15         | 15               | M20x1.5                | 59             | 28             | 12 | 15             | 24 | 67019         |

**FLH 直角内外螺纹**  
FLH Male stud elbow

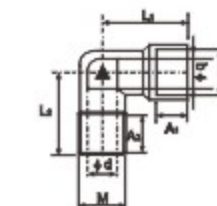

| 型号 d(mm) Model | 公称通径 Φd Pipe dia | 接口螺纹 M Coupling thread | L <sub>1</sub> | L <sub>2</sub> | A  | A <sub>2</sub> | D  | 订货号 Order no. |
|----------------|------------------|------------------------|----------------|----------------|----|----------------|----|---------------|
| FLH-4          | 4                | M8x1                   | 37             | 18.5           | 7  | 6              | 12 | 67020         |
| FLH-6          | 6                | M10x1                  | 39             | 19.5           | 8  | 9              | 12 | 67021         |
| FLH-8          | 8                | M12x1.25               | 47             | 23.5           | 11 | 11             | 17 | 67022         |
| FLH-10         | 10               | M16x1.5                | 52             | 26             | 12 | 13             | 20 | 67023         |
| FLH-15         | 15               | M20x1.5                | 59             | 28             | 12 | 15             | 24 | 67024         |

**YWS 内置轴承高低速旋转接头系列**  
YWS built-in bearing high-low-speed rotary connector series

**YWS-C 直通可 360° 不间断旋转快插式**

YWS-C straight quick-insert type that can make interrupted rotation for 360°.



| 型号 Model   | D  | R    | P    | E    | C  | L    | A    | SxΦ     | PRM | 订货号 Order no. |
|------------|----|------|------|------|----|------|------|---------|-----|---------------|
| YWS-C04-M5 | 4  | M5   | 10.5 | 20   | 17 | 36.5 | 5    | 12x13   | 500 | 67449         |
| YWS-C04-01 | 4  | 1/8" | 10.5 | 20   | 17 | 36.5 | 8.5  | 12x13   | 500 | 67450         |
| YWS-C04-02 | 4  | 1/4" | 10.5 | 20   | 17 | 39.5 | 11   | 14x15.5 | 500 | 67451         |
| YWS-C06-M5 | 6  | M5   | 12.5 | 22.5 | 19 | 39.5 | 5    | 12x13   | 500 | 67452         |
| YWS-C06-01 | 6  | 1/8" | 12.5 | 22.5 | 19 | 39.5 | 8.5  | 12x13   | 500 | 67433         |
| YWS-C06-02 | 6  | 1/4" | 12.5 | 22.5 | 19 | 42   | 11   | 14x15.5 | 500 | 67454         |
| YWS-C08-01 | 8  | 1/8" | 14.5 | 25.5 | 21 | 44.6 | 8.5  | 17x18   | 500 | 67455         |
| YWS-C08-02 | 8  | 1/4" | 14.5 | 25.5 | 21 | 46.6 | 11   | 17x18   | 500 | 67456         |
| YWS-C08-03 | 8  | 3/8" | 14.5 | 33.5 | 25 | 53.5 | 11   | 19x20.5 | 250 | 67457         |
| YWS-C08-04 | 8  | 1/2" | 14.5 | 33.5 | 25 | 55   | 12.5 | 21x23.5 | 250 | 67458         |
| YWS-C10-02 | 10 | 1/4" | 16.5 | 41   | 34 | 62   | 11   | 21x23.5 | 500 | 67459         |
| YWS-C10-03 | 10 | 3/8" | 16.5 | 41   | 34 | 62   | 11   | 21x23.5 | 250 | 67460         |
| YWS-C10-04 | 10 | 1/2" | 16.5 | 41   | 34 | 63.5 | 12.5 | 21x23.5 | 250 | 67461         |
| YWS-C12-03 | 12 | 3/8" | 18.5 | 44   | 37 | 65.5 | 11   | 22x24   | 250 | 67462         |
| YWS-C12-04 | 12 | 1/2" | 18.5 | 44   | 37 | 67   | 12.5 | 22x24   | 250 | 67463         |

**YWS-L 直角可 360° 不间断旋转快插式**

YWS-L straight quick-insert type that can make interrupted rotation for 360°.

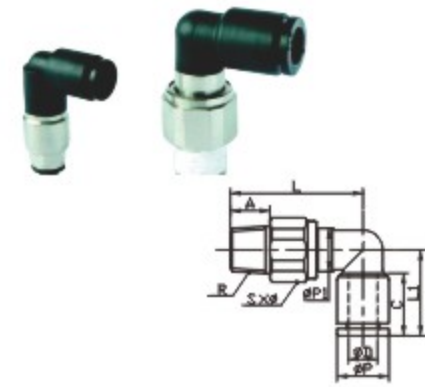

| 型号 Model   | D  | R    | P    | P <sub>1</sub> | L <sub>1</sub> | C  | L    | A    | SxΦ     | PRM | 订货号 Order no. |
|------------|----|------|------|----------------|----------------|----|------|------|---------|-----|---------------|
| YWS-L04-M5 | 4  | M5   | 10.5 | 11             | 18             | 14 | 28   | 5    | 12x13   | 500 | 67464         |
| YWS-L04-01 | 4  | 1/8" | 10.5 | 11             | 18             | 14 | 28   | 8.5  | 12x13   | 500 | 67465         |
| YWS-L04-02 | 4  | 1/4" | 10.5 | 11             | 18             | 14 | 28   | 44   | 14x15.5 | 500 | 67466         |
| YWS-L06-M5 | 6  | M5   | 12.5 | 12             | 20.2           | 15 | 30.5 | 5    | 12x13   | 500 | 67467         |
| YWS-L06-01 | 6  | 1/8" | 12.5 | 12             | 20.2           | 15 | 34   | 8.5  | 12x13   | 500 | 67468         |
| YWS-L06-02 | 6  | 1/4" | 12.5 | 12             | 20.2           | 15 | 36.5 | 11   | 14x15.5 | 500 | 67469         |
| YWS-L08-01 | 8  | 1/8" | 14.5 | 12             | 23.8           | 18 | 34.5 | 8.5  | 17x18   | 500 | 67470         |
| YWS-L08-02 | 8  | 1/4" | 14.5 | 12             | 23.8           | 18 | 37   | 11   | 17x18   | 500 | 67471         |
| YWS-L08-03 | 8  | 3/8" | 14.5 | 12             | 23.8           | 18 | 37   | 11   | 19x20.5 | 250 | 67472         |
| YWS-L08-04 | 8  | 1/2" | 14.5 | 12             | 23.8           | 18 | 38.5 | 12.5 | 21x23.5 | 250 | 67473         |
| YWS-L10-02 | 10 | 1/4" | 17.5 | 16             | 27.5           | 20 | 37.5 | 11   | 21x23.5 | 500 | 67474         |
| YWS-L10-03 | 10 | 3/8" | 17.5 | 16             | 27.5           | 20 | 37.5 | 11   | 21x23.5 | 250 | 67475         |
| YWS-L10-04 | 10 | 1/2" | 17.5 | 16             | 27.5           | 20 | 39   | 12.5 | 21x23.5 | 250 | 67476         |
| YWS-L12-03 | 12 | 3/8" | 18.5 | 20             | 30.5           | 22 | 39.4 | 11   | 22x24   | 250 | 67477         |
| YWS-L12-04 | 12 | 1/2" | 18.5 | 20             | 30.5           | 22 | 41   | 12.5 | 22x24   | 250 | 67478         |

**YWS-CR 直通可 360° 不间断旋转快插式**

YWS-CR straight quick-insert type that can make interrupted rotation for 360°.

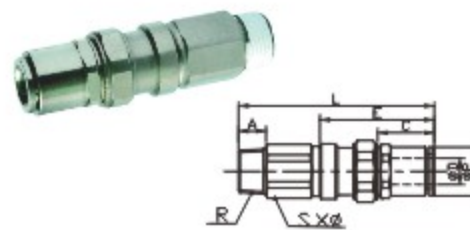

| 型号 Model    | D  | R    | P    | E    | C    | L    | A    | SxΦ     | PRM | 订货号 Order no. |
|-------------|----|------|------|------|------|------|------|---------|-----|---------------|
| YWS-CR04-M5 | 4  | M5   | 9.8  | 31.5 | 15.5 | 53   | 5    | 12x13   | 500 | 67479         |
| YWS-CR04-01 | 4  | 1/8" | 9.8  | 31.5 | 15.5 | 55.5 | 8.5  | 12x13   | 500 | 67480         |
| YWS-CR04-02 | 4  | 1/4" | 9.8  | 31.5 | 15.5 | 58   | 11   | 14x15.5 | 500 | 67481         |
| YWS-CR06-M5 | 6  | M5   | 11.8 | 35.5 | 17.5 | 55   | 5    | 12x13   | 500 | 67482         |
| YWS-CR06-01 | 6  | 1/8" | 11.8 | 35.5 | 17.5 | 57.5 | 8.5  | 12x13   | 500 | 67483         |
| YWS-CR06-02 | 6  | 1/4" | 11.8 | 35.5 | 17.5 | 60   | 11   | 14x15.5 | 500 | 67484         |
| YWS-CR08-01 | 8  | 1/8" | 13.8 | 39.5 | 19.5 | 61   | 8.5  | 17x18   | 500 | 67485         |
| YWS-CR08-02 | 8  | 1/4" | 13.8 | 39.5 | 19.5 | 63.5 | 11   | 17x18   | 500 | 67486         |
| YWS-CR08-03 | 8  | 3/8" | 13.8 | 39.5 | 19.5 | 63.5 | 11   | 19x20.5 | 250 | 67487         |
| YWS-CR08-04 | 8  | 1/2" | 13.8 | 39.5 | 19.5 | 65   | 12.5 | 19x20.5 | 250 | 67488         |
| YWS-CR10-02 | 10 | 1/4" | 15.8 | 43.5 | 21.5 | 69.5 | 11   | 19x20.5 | 500 | 67489         |
| YWS-CR10-03 | 10 | 3/8" | 15.8 | 43.5 | 21.5 | 69.5 | 11   | 19x20.5 | 250 | 67490         |
| YWS-CR10-04 | 10 | 1/2" | 16.5 | 43.5 | 21.5 | 71   | 12.5 | 21x23.5 | 250 | 67491         |
| YWS-CR12-03 | 12 | 3/8" | 17.8 | 47.5 | 23.5 | 72.5 | 11   | 22x24   | 250 | 67492         |
| YWS-CR12-04 | 12 | 1/2" | 17.5 | 47.5 | 23.5 | 74   | 12.5 | 22x24   | 250 | 67493         |

**通用附件(全铜镀镍)**  
Metal interconverted accessories (brass & nickel-plate)

**FM 堵头 FM Sealing fittings**



| 型号 Model | A     | B   | C   | D  | 订货号 Order no. |
|----------|-------|-----|-----|----|---------------|
| FM-2     | M5    | 4.5 | 3.5 | 8  | 67561         |
| FM-4     | G1/8" | 8   | 3   | 12 | 67562         |
| FM-6     | G1/4" | 12  | 3   | 14 | 67563         |
| FM-8     | G3/8" | 12  | 3   | 17 | 67564         |
| FM-10    | G1/2" | 14  | 4   | 22 | 67565         |
| FM-12    | G3/4" | 16  | 4   | 27 | 67566         |

**FJ 变径二通接头(内外螺纹)**

FJ Reducer straight stud(male & female)

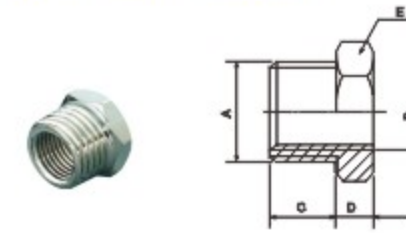

| 型号 Model | A       | B     | C  | D | E  | 订货号 Order no. |
|----------|---------|-------|----|---|----|---------------|
| FJ-2     | G1/8"   | M5    | 7  | 4 | 12 | 67567         |
| FJ-4     | G1/4"   | G1/8" | 10 | 5 | 17 | 67568         |
| FJ-6     | G3/8"   | G1/8" | 10 | 5 | 19 | 67569         |
| FJ-8     | G3/8"   | G1/4" | 10 | 5 | 19 | 67570         |
| FJ-10    | G1/2"   | G1/8" | 12 | 7 | 22 | 67571         |
| FJ-12    | G1/2"   | G1/4" | 12 | 7 | 22 | 67572         |
| FJ-14    | G1/2"   | G3/8" | 12 | 7 | 22 | 67573         |
| FJ-16    | G3/4"   | G1/4" | 12 | 7 | 27 | 67574         |
| FJ-18    | G3/4"   | G3/8" | 12 | 7 | 27 | 67575         |
| FJ-20    | G1/4"   | G1/2" | 12 | 7 | 27 | 67576         |
| FJ-22    | G1/4"   | M10x1 | 10 | 5 | 14 | 67577         |
| FJ-24    | M14x1.5 | M10x1 | 10 | 5 | 17 | 67578         |
| FJ-26    | M14x1.5 | G1/8" | 10 | 5 | 17 | 67579         |

**FB 直通内外螺纹接头**

FB Straight male & female stud



| 型号 Model | A     | B    | C  | C <sub>1</sub> | D  | E  | 订货号 Order no. |
|----------|-------|------|----|----------------|----|----|---------------|
| FB-2     | M5    | 1/8" | 8  | 5              | 10 | 12 | 67580         |
| FB-6     | G1/8" | 1/4" | 11 | 7              | 13 | 17 | 67581         |
| FB-8     | G1/4" | 3/8" | 12 | 9              | 15 | 19 | 67582         |
| FB-12    | G3/8" | 1/2" | 12 | 11             | 15 | 24 | 67583         |
| FB-16    | G1/2" | 3/4" | 13 | 12             | 16 | 32 | 67584         |

**FS 直通接头(外双螺纹)**

FS Straight male union(double male)

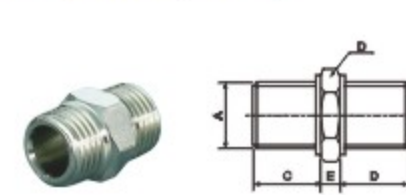

| 型号 Model | A     | B     | C  | D  | E | E  | 订货号 Order no. |
|----------|-------|-------|----|----|---|----|---------------|
| FS-2     | M5    | M5    | 5  | 5  | 4 | 8  | 67585         |
| FS-4     | G1/8" | M5    | 7  | 5  | 5 | 12 | 67586         |
| FS-6     | G1/8" | G1/8" | 7  | 7  | 4 | 12 | 67587         |
| FS-8     | G1/8" | G1/4" | 7  | 10 | 5 | 14 | 67588         |
| FS-10    | G1/4" | G1/4" | 10 | 10 | 5 | 14 | 67589         |
| FS-12    | G1/4" | G3/8" | 10 | 10 | 5 | 19 | 67590         |
| FS-14    | G3/8" | G3/8" | 10 | 10 | 5 | 19 | 67591         |
| FS-16    | G3/8" | G1/2" | 10 | 12 | 6 | 22 | 67592         |
| FS-18    | G1/2" | G1/2" | 12 | 12 | 6 | 22 | 67593         |
| FS-20    | G1/2" | G3/4" | 12 | 12 | 7 | 27 | 67594         |
| FS-22    | G3/4" | G3/4" | 12 | 12 | 7 | 27 | 67595         |
| FS-24    | G3/4" | G1    | 12 | 15 | 8 | 36 | 67596         |
| FS-26    | G1"   | G     | 15 | 15 | 8 | 36 | 67597         |

**FD 等径接头(内双螺纹)**

FD Straight female union(double female)

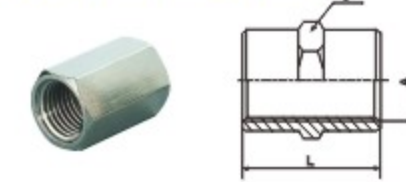

| 型号 Model | A     | L  | S  | 订货号 Order no. |
|----------|-------|----|----|---------------|
| FD-2     | M5    | 11 | 8  | 67598         |
| FD-4     | G1/8" | 15 | 14 | 67599         |
| FD-6     | G1/4" | 22 | 17 | 67600         |
| FD-10    | G3/8" | 24 | 22 | 67601         |
| FD-15    | G1/2" | 30 | 26 | 67602         |
| FD-20    | G3/4" | 31 | 32 | 67603         |
| FD-25    | G1"   | 50 | 45 | 67604         |

## PU气管



### 特点

具有极好的耐高压、耐振动、耐腐蚀、耐气候、耐曲折性能  
重量轻,使用方便灵活,便于布管作业  
内外径尺寸精度控制高,适合各种接头  
多种颜色可供选择

### 气管颜色



| 编号 | 4 | 6 | 8 | 10 | 12 |
|----|---|---|---|----|----|
|----|---|---|---|----|----|

### 订购码

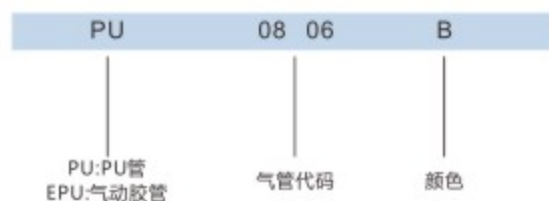

### 使用须知:

- 1.请勿管给接头外加拉力、卷绕、弯曲等负荷否则有导致接头损坏的危险。
- 2.不要使用温度60°C以上的水热介质油,因热及加水会导致接头破裂
- 3.请勿使用空气、水(有条件)以外的其他流体介质。

### 装配管子时注意事项:

- 1.要检查管子的表面有无伤痕或是否变成椭圆形。
- 2.装配管子时一定要把管子末端插到接头的底部(即管头的定位孔处),管子若未完全插到底有可能漏气。
- 3.管子装配完后,以确保用手拉时管子不会被拉出来(不要用力拉,否则可能损坏接头)。

### 松开管子时注意事项:

- 1.松开管子之前,确保管子内的压力为零。
- 2.将释放环均衡地压到底,并将管子拔出,若释放环未完全推入,有可能管子无法拉出或拉伤管子,并且接头内将留下管子的管屑,导致以后使用可能造成漏气。

### 装配管子时,管子的外径尺寸要满足一定的公差要求:

氨基甲酸乙PU管规格4、6、8、10在±0.1mm内,规格10,12在±0.15mm内。

### PU管标准规格明细表

| 代码                      | PU0302 | PU0425 | PU0640 | PU0850 | PU1065 | PU1280 | PU1611 |
|-------------------------|--------|--------|--------|--------|--------|--------|--------|
| 外径(mm)                  | Φ3.0   | Φ4.0   | Φ6.0   | Φ8.0   | Φ10.0  | Φ12.0  | Φ16.0  |
| 内径(mm)                  | Φ2.0   | Φ2.5   | Φ4.0   | Φ5     | Φ6.5   | Φ8.0   | Φ11.0  |
| 工作压力 kg/cm <sup>2</sup> | 10     | 10     | 10     | 10     | 10     | 10     | 10     |

### EPU管标准规格明细表

| 外径×内径  | 长度  | 工作压力  |
|--------|-----|-------|
| mm×mm  | m   | kg/cc |
| 4×2.5  | 200 | 8     |
| 6×4    | 200 | 8     |
| 8×5    | 100 | 8     |
| 10×6.5 | 100 | 8     |
| 12×8   | 100 | 8     |

## PA气管



### 特点

具有极好的耐高压、耐振动、耐腐蚀、耐气候、耐曲折性能  
重量轻,使用方便灵活,便于布管作业  
内外径尺寸精度控制高,适合各种接头  
多种颜色可供选择

### 气管颜色



### 订购码



### 使用须知:

- 1.请勿管给接头外加拉力、卷绕、弯曲等负荷否则有导致接头损坏的危险。
- 2.不要使用温度60°C以上的水热介质油,因热及加水会导致接头破裂
- 3.请勿使用空气、水(有条件)以外的其他流体介质。

### 装配管子时注意事项:

- 1.要检查管子的表面有无伤痕或是否变成椭圆形。
- 2.装配管子时一定要把管子末端插到接头的底部(即管头的定位孔处),管子若未完全插到底有可能漏气。
- 3.管子装配完后,以确保用手拉时管子不会被拉出来(不要用力拉,否则可能损坏接头)。

### 松开管子时注意事项:

- 1.松开管子之前,确保管子内的压力为零。
- 2.将释放环均衡地压到底,并将管子拔出,若释放环未完全推入,有可能管子无法拉出或拉伤管子,并且接头内将留下管子的管屑,导致以后使用可能造成漏气。

### 装配管子时,管子的外径尺寸要满足一定的公差要求:

尼龙管(PA)规格4、6、8、10、12在±0.1mm内

### PA尼龙管标准规格明细表

| 代码                      | PA0302 | PA0425 | PA0640 | PA0850 | PA1065 | PA1280 | PA1611 |
|-------------------------|--------|--------|--------|--------|--------|--------|--------|
| 外径(mm)                  | Φ3.0   | Φ4.0   | Φ6.0   | Φ8.0   | Φ10.0  | Φ12.0  | Φ16.0  |
| 内径(mm)                  | Φ2.0   | Φ2.5   | Φ4.0   | Φ5     | Φ6.5   | Φ8.0   | Φ11.0  |
| 工作压力 kg/cm <sup>2</sup> | 24     | 24     | 24     | 24     | 24     | 24     | 24     |

备忘录  
MEMORANDUM

Lined area for writing the memorandum content.